

Gas Fired Breakers

Model: CHG9

Parts Manual CHG-Series



Part #CHGE00014

Connect Work Tools - www.connectworktools.com - 920.238.6657

Table of Contents

Contact Information	4
1.0 Equipment Identification	
1.1 Location of Serial Number	5
1.2 Owner's Record of Equipment	5
2.0 Decals	6
3.0 Base Plates	8
4.0 CHG9 Hammer	
4.1 Hammer	10
4.2 Back Head Sub Assembly	11
4.3 Cylinder Sub Assembly	12
4.4 Front Head Sub Assembly	14
4.5 Side Rod Set	15
5.0 CHG9 Housing	
5.1 Box Housing	16

Contact Information



Connect Work Tools
155 Main Street
Superior, WI 54880

E-mail: info@connectworktools.com
Main Phone: 920-238-6657
Fax: 715-395-3703

Contact your Connect Work Tools Representative or the Connect Work Tools Parts Department for replacement manuals. Inquiries regarding the content of this manual must include the release date shown below.

Information in this manual is subject to change without advance notice.

Table 1.1 About this manual

Document ID No.	CHGE00014
Type	Parts
Release Date	January 2024
Product Name	Gas fired Breakers
Series	CHG
Applicable Models	CHGE
Years of Manufacture	2024 & above

1.0 Equipment Identification

1.1 Location of the Serial Number Decal

Models: CHG2/CHG3/CHG6/CHG7/
CHG9/ CHG10/CHG15

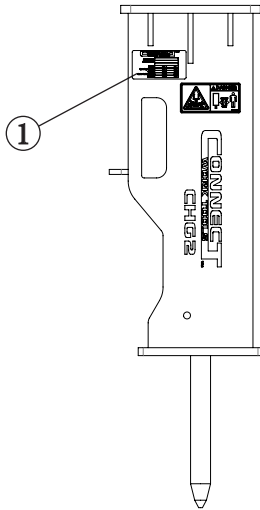

The Serial Equipment Identification Decal is affixed to the side of the housing box. It provides the following information:

- Serial Number
- Model
- Part Number
- Weight
- Operating Pressure
- Oil Flow
- Carrier Relief Pressure
- Nitrogen

****Note: Prior to ordering parts, it's important to confirm your model and serial number**

CONNECT™ WORK TOOLS			
Serial Number:			
Model Number:			
Weight:	kg		lb
Operating Pressure:	bar		psi
Oil Flow:	l/min		gpm
Carrier Relief Pressure:	bar		psi
Nitrogen:	bar		psi

1.2 Owner's Record of the Equipment

Record the Model and Serial Number from the Serial Equipment Identification Tag to the space provided below. Indicate the date in which the Connect Work Tools equipment was placed into service.

Model CHG2: CHG2
 Model CHG3: CHG3
 Model CHG6: CHG6
 Model CHG7: CHG7
 Model CHG9: CHG9
 Model CHG10: CHG10
 Model CHG15: CHG15

Serial Number: _____

In Service Date: _____

Your Connect Work Tools representative requires this information to better assist you with questions regarding parts, warranty, operation, maintenance, or repair.

Your equipment must be registered by your local Distributor at the time of sale.

Product Registration Date: _____

2.0 Decals

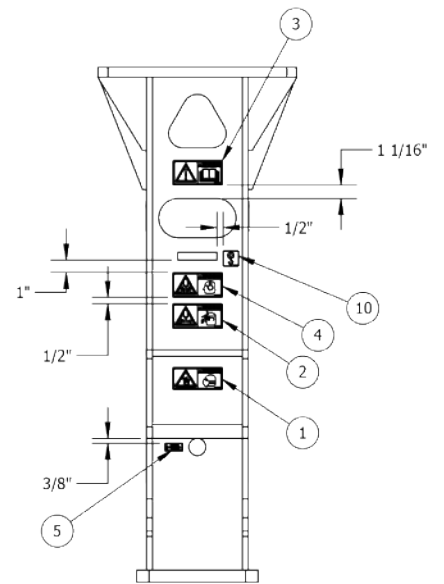
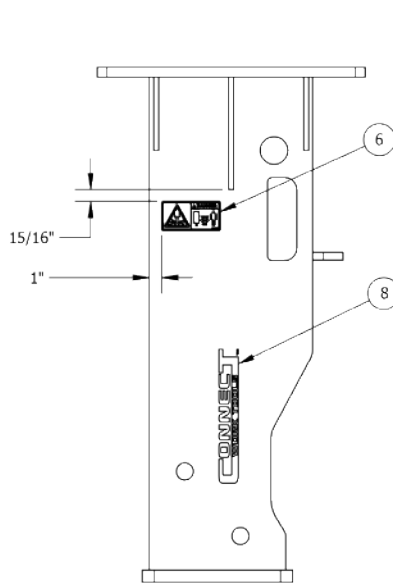
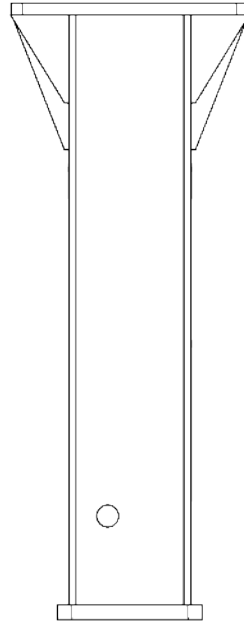
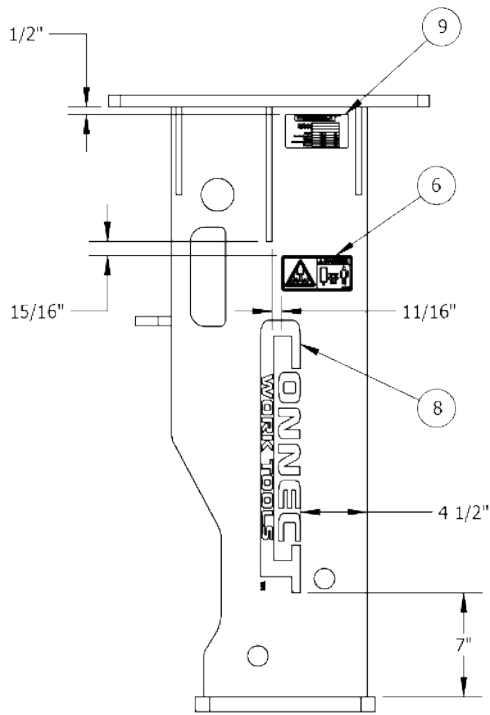

2.0 Decals

All decals pictured are included in decal kits (with exception of No. 10)

2.1 Standard Decals



1. Part Number 16-00076 - Decal Warning Dust



2. Part Number 16-00077 - Decal Warning Flying Objects



3. Part Number 16-00078 - Decal Warning Read Manual



4. Part Number 16-00079 - Decal Warning Noise



5. Part Number 16-00080 - Decal Grease Point



6. Part Number 16-00086 - Decal Warning Safe Distance



7. Part Number CHG00007 - Decal CHG9



8. Part Number CHE00166 - Decal Connect Logo 11" - CHG2/CHG3/CHG6/CHG7
Part Number CHE00109 - Decal Connect Logo 18" - CHG9/CHG10/CHG15



9. Part Number CHE00127 - Decal SN Plate (Not included in Decal Kit)



10. Part Number 16-00082 - Decal Lift Point



11. Part Number CHE00111 - Decal Warning Nitrogen

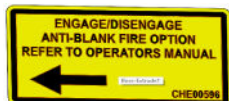

12. Part Number CHE00596 - Decal Warning Anti-Blank Fire

3.0 Base Plates

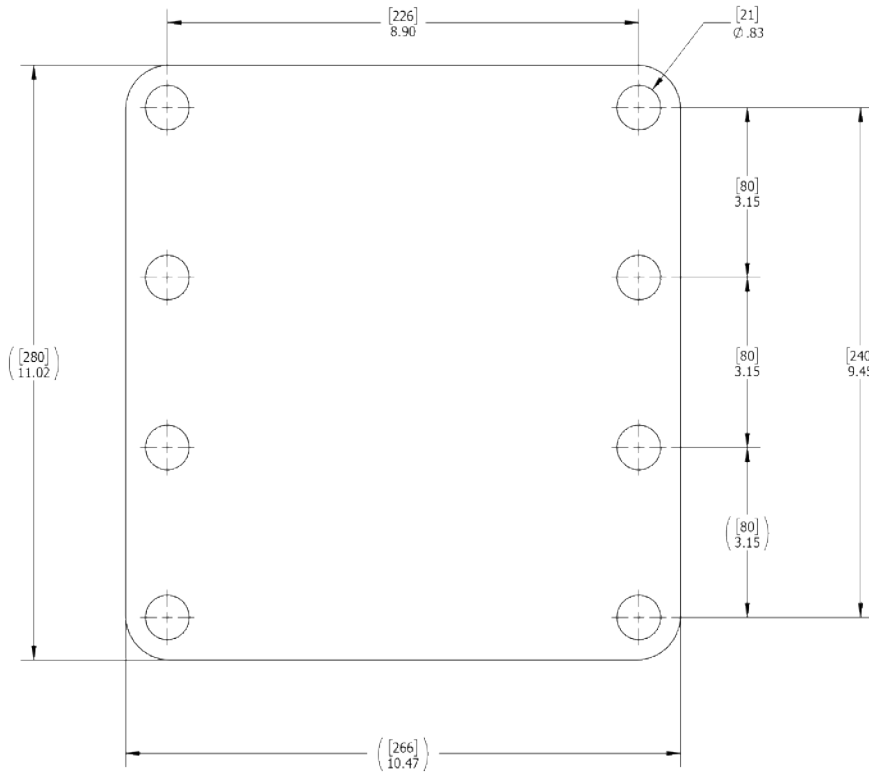

CHGE00101 - CHG2 - BASE PLATE

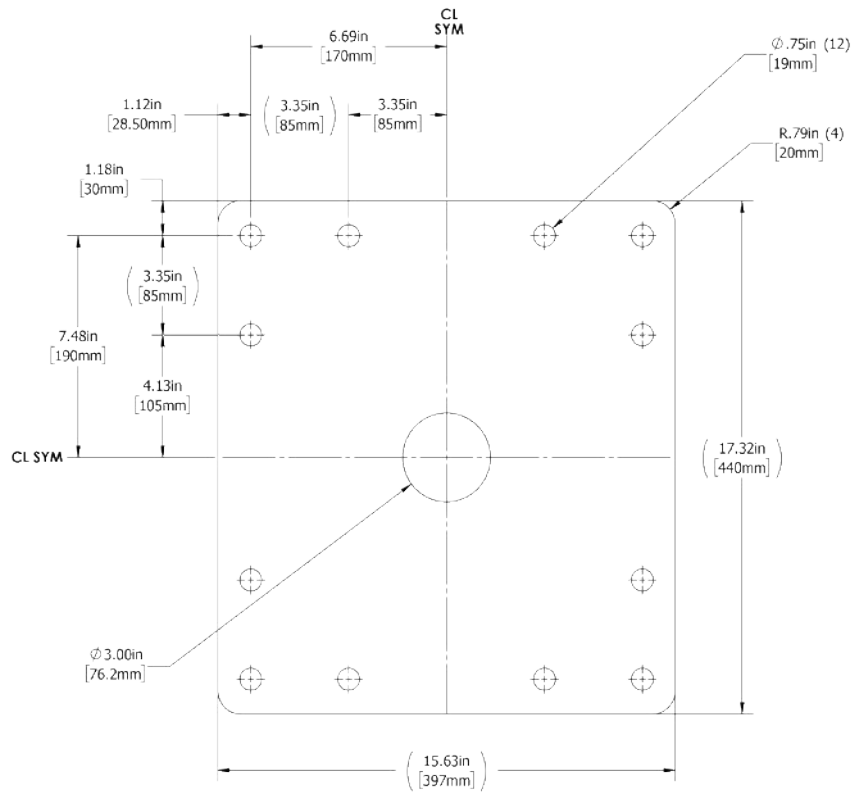

CHE00100 - CHG3/CHG6/CHG7 - BASE PLATE

3.0 Base Plates

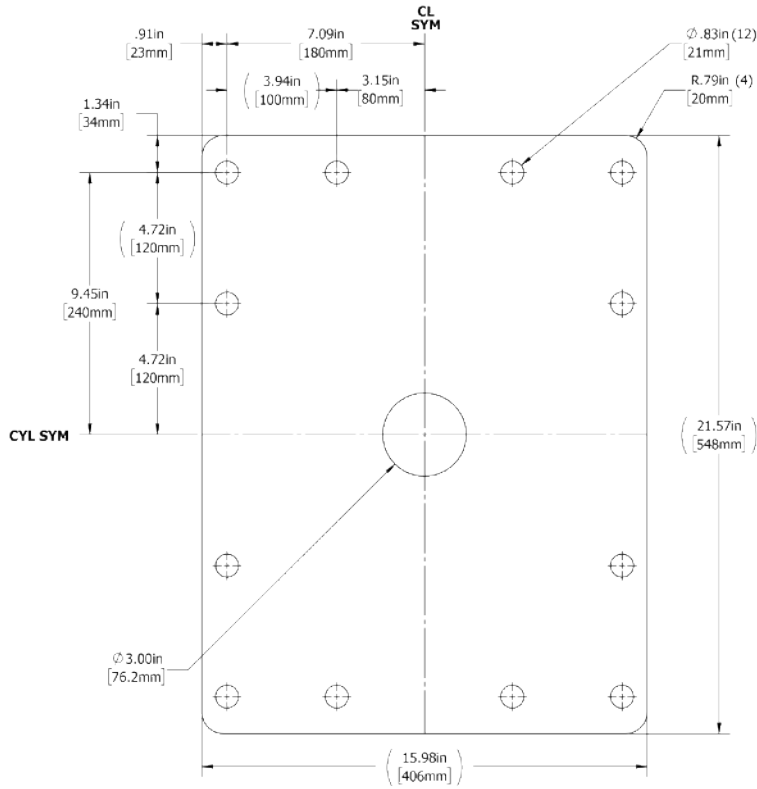

CHE00101 - CHG9/CHG10 - BASE PLATE

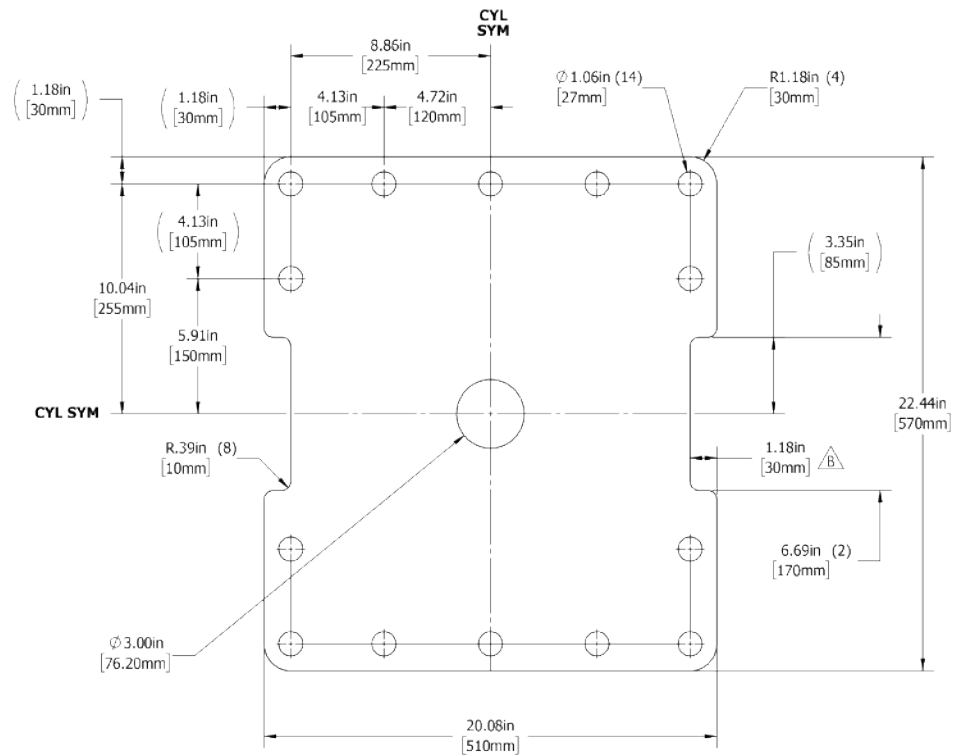

CHE00103 - CHG15 - BASE PLATE

4.0 CHG9 Hammer

4-1. Hammer

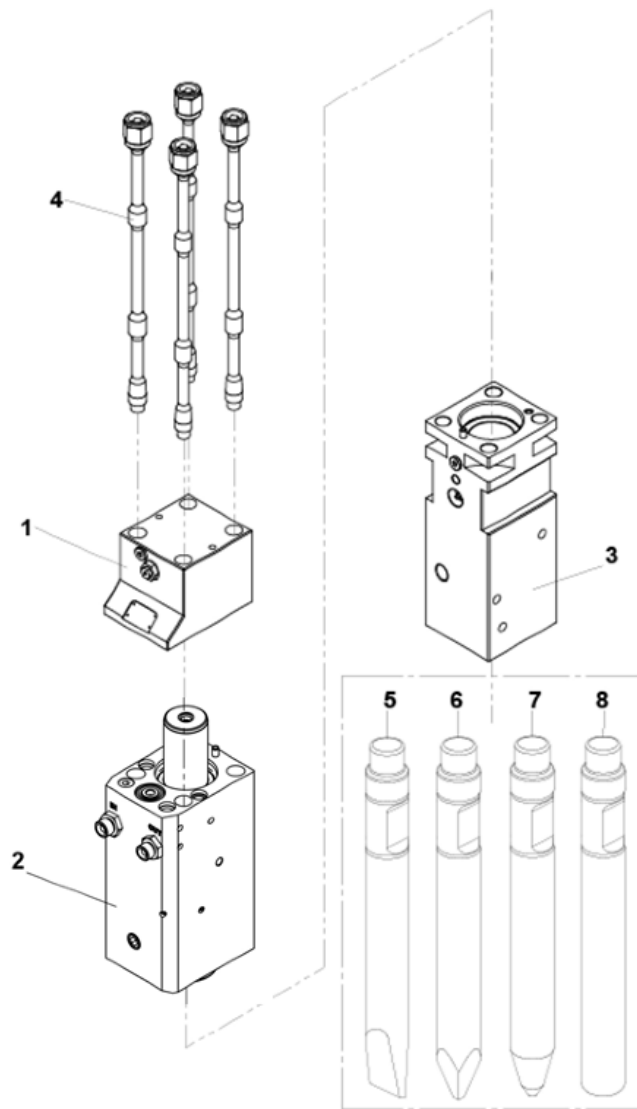

NO.	PART NO.	PART NAME	QTY	REMARKS
	CHG0920000	HAMMER TOTAL ASSEMBLY	1	
1	CHG0921000	BACK HEAD SUB ASSEMBLY	1	
2	CHG0922000	CYLINDER SUB ASSEMBLY	1	
3	CHG0923000	FRONT HEAD SUB ASSEMBLY	1	
4	CHG0924000	SIDE ROD SET	4	
5	CHG0925000	CHG9 CHISEL	1	
6	CHG0926000	CHG9 MOIL	1	
7	CHG0927000	CHG9 CONE	1	
8	CHG0928000	CHG9 BLUNT	1	
	CHG0930000	CHG9 SEAL KIT	1	

4.0 CHG9 Hammer

4-2. Back Head Sub Assembly

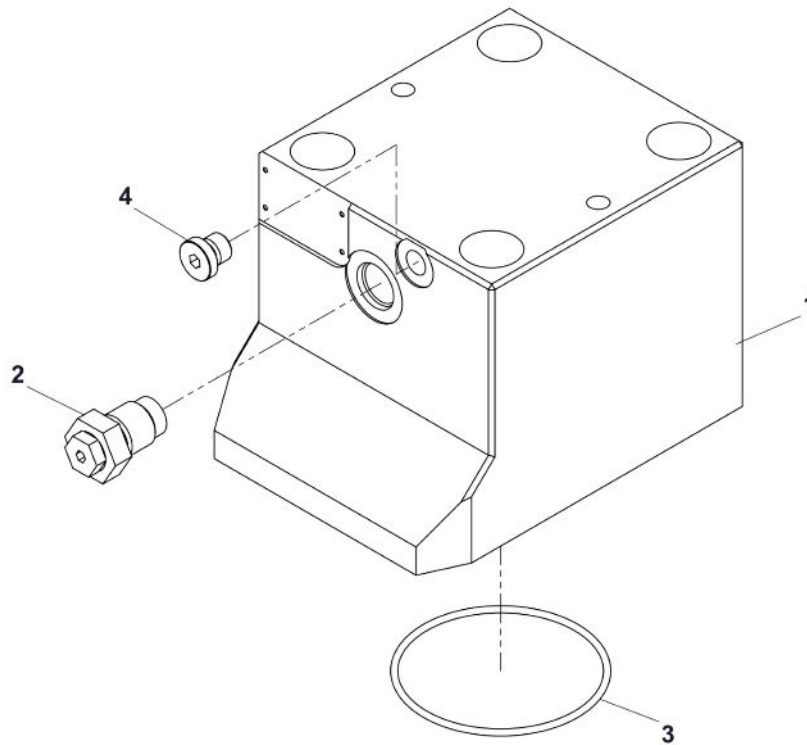

NO.	PART NO.	PART NAME	QTY	REMARKS
	CHG0921000	BACK HEAD SUB ASSEMBLY	1	
1	CHG0921001	CHG9 BACK HEAD	1	
2	CHG0201003	GAS CHARGING VALVE ASSEMBLY	1	
3	CHG0921003	O-RING	1	PART OF SEAL KIT
4	CHG0921004	PLUG	1	

4.0 CHG9 Hammer

4-3. Cylinder Sub Assembly

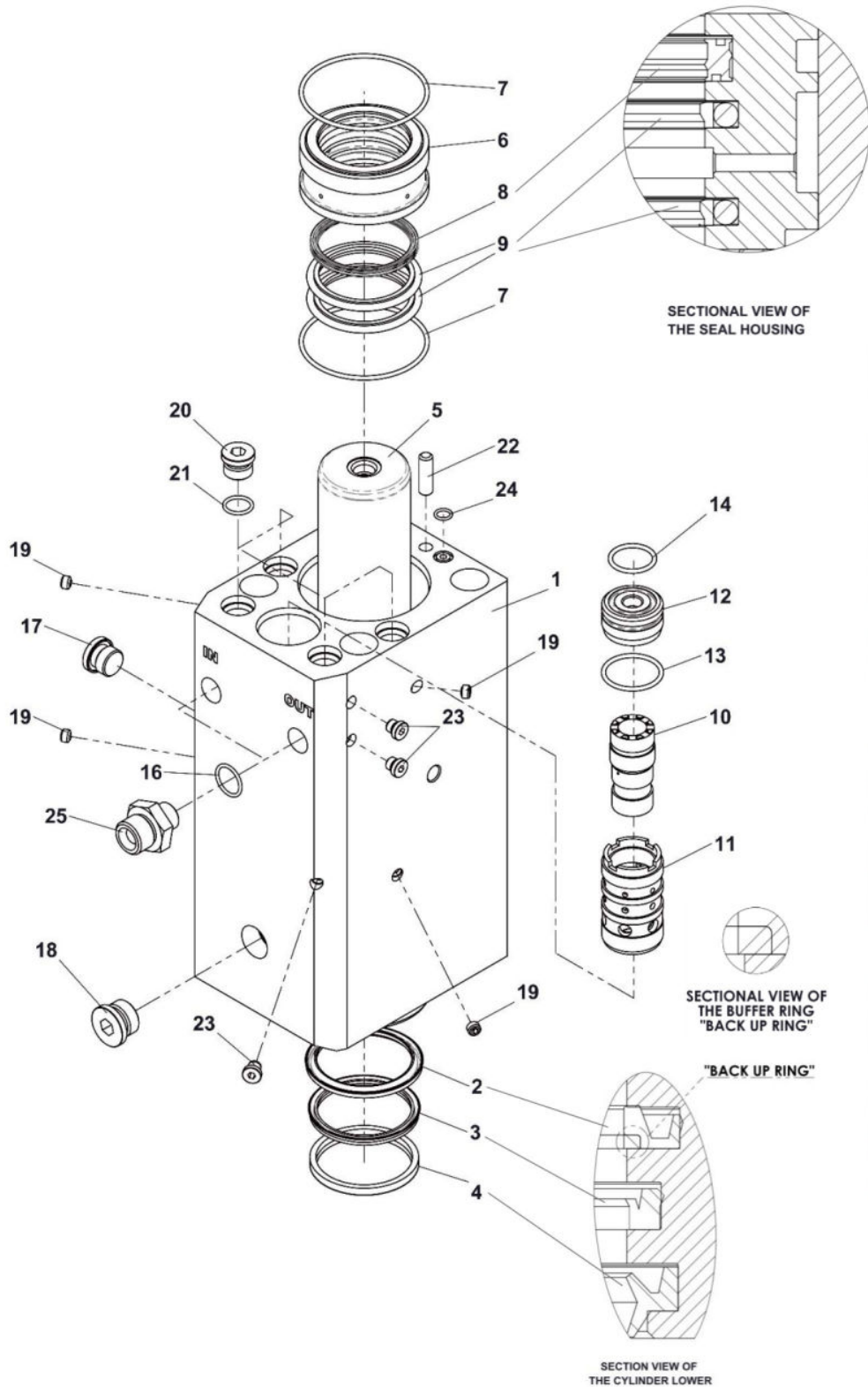

4.0 CHG9 Hammer

NO.	PART NO.	PART NAME	QTY	REMARKS
	CHG0922000	CYLINDER SUB ASSEMBLY	1	
1	CHG0922001	CHG9 CYLINDER	1	
2	CHG0922002	BUFFER RING	1	PART OF SEAL KIT
3	CHG0722002	U-PACKING	1	PART OF SEAL KIT
4	CHG0722003	WIPER	1	PART OF SEAL KIT
5	CHG0922005	PISTON	1	
6	CHG0922006	SEAL HOUSING	1	
7	CHG0921003	O-RING	2	PART OF SEAL KIT
8	CHG0722007	GAS SEAL	1	PART OF SEAL KIT
9	CHG0722008	STEP SEAL	2	PART OF SEAL KIT
10	CHG0922010	OPER. VALVE SPOOL	1	
11	CHG0922011	OPER. VALVE GUIDE	1	
12	CHG0922012	OPER. VALVE COVER	1	
13	CHG0922013	O-RING	1	PART OF SEAL KIT
14	CHG0922014	O-RING	1	PART OF SEAL KIT
16	CHG0202013	O-RING	2	OPTION
17	CHG0722016	PLUG	1	
18	CHG0602014	SOCKET PLUG	1	
19	CHG0722017	SET SCREW	4	
20	CHG0722018	SOCKET PLUG	4	
21	CHG0722019	-RING	4	PART OF SEAL KIT
22	CHG0600011	GUIDE PIN	1	
23	CHG0602013	SOCKET PLUG	3	
24	CHG0722023	O-RING	1	PART OF SEAL KIT
25	CHG0922025	ADAPTER	2	PF 3/4" - OPTION

4.0 CHG9 Hammer

4-4. Front Head Sub Assembly

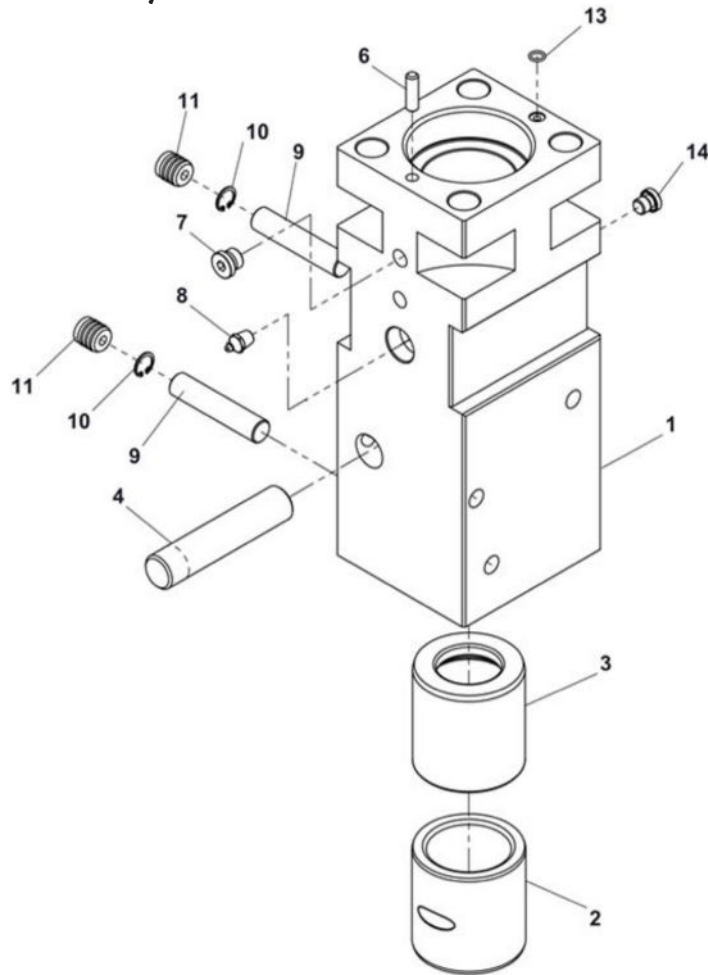

NO.	PART NO.	PART NAME	QTY	REMARKS
	CHG0923000	FRONT HEAD SUB ASSEMBLY	1	
1	CHG0923001	CHG9 FRONT HEAD	1	
2	CHG0923002	CHG9 TOOL BUSHING	1	
3	CHG0923003	CHG9 THRUST BUSH	1	
4	CHG0923015	CHG9 TOOL PIN	1	
6	CHG0600011	GUIDE PIN	1	
7	CHG0722016	SOCKET PLUG	1	
8	CHG0203004	GREASE NIPPLE	1	
9	CHG0923009	STOP PIN	2	
10	CHG0923010	SNAP PLUG	2	
11	CHG0923011	REBBER PLUG	2	
13	CHG0722023	O-RING	1	PART OF SEAL KIT
14	CHG0202011	PLUG	1	

4.0 CHG9 Hammer

4-5. Side Rod Set

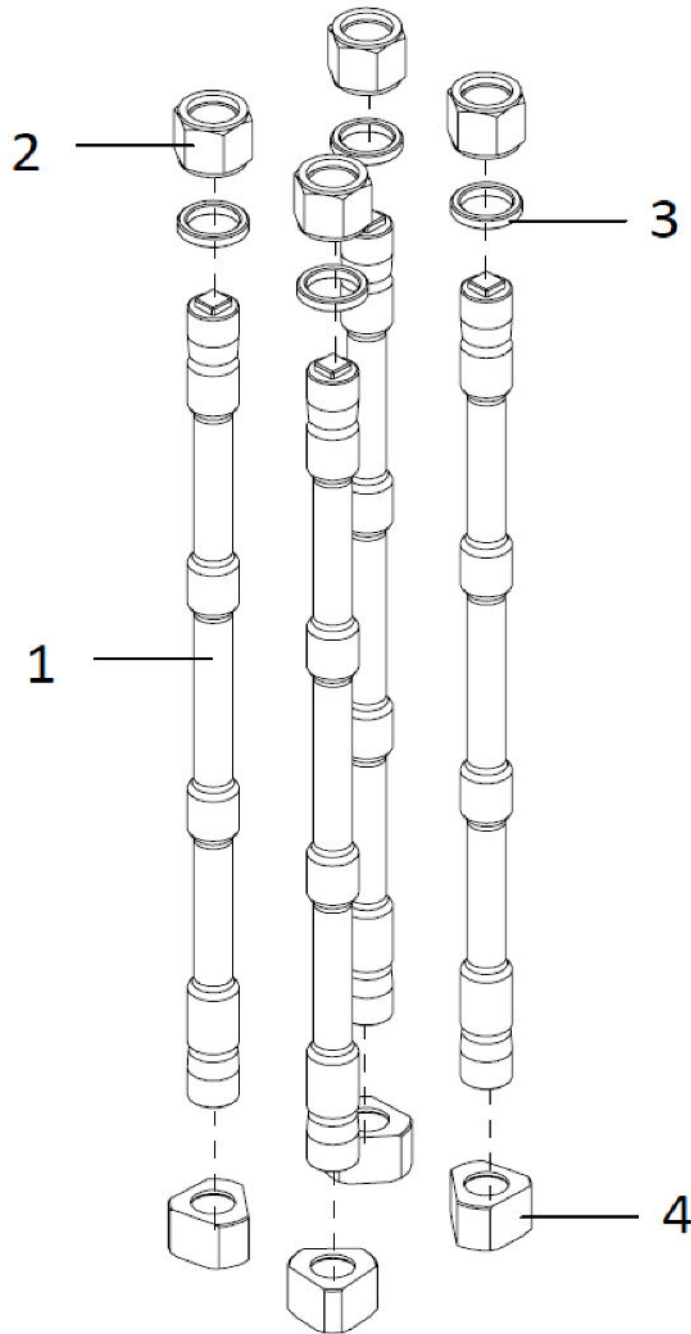

NO.	PART NO.	PART NAME	QTY	REMARKS
	CHG0924000	SIDE ROD SET	4	
1	CHG0924001	CHG9 SIDE ROD	4	
2	CHG0924002	SIDE ROD NUT (UPPER)	4	
3	CHG0924004	SIDE ROD WASHER	4	
4	CHG0924003	SIDE ROD NUT (LOWER)	4	

5.0 CHG9 Housing

5-1. Box Housing

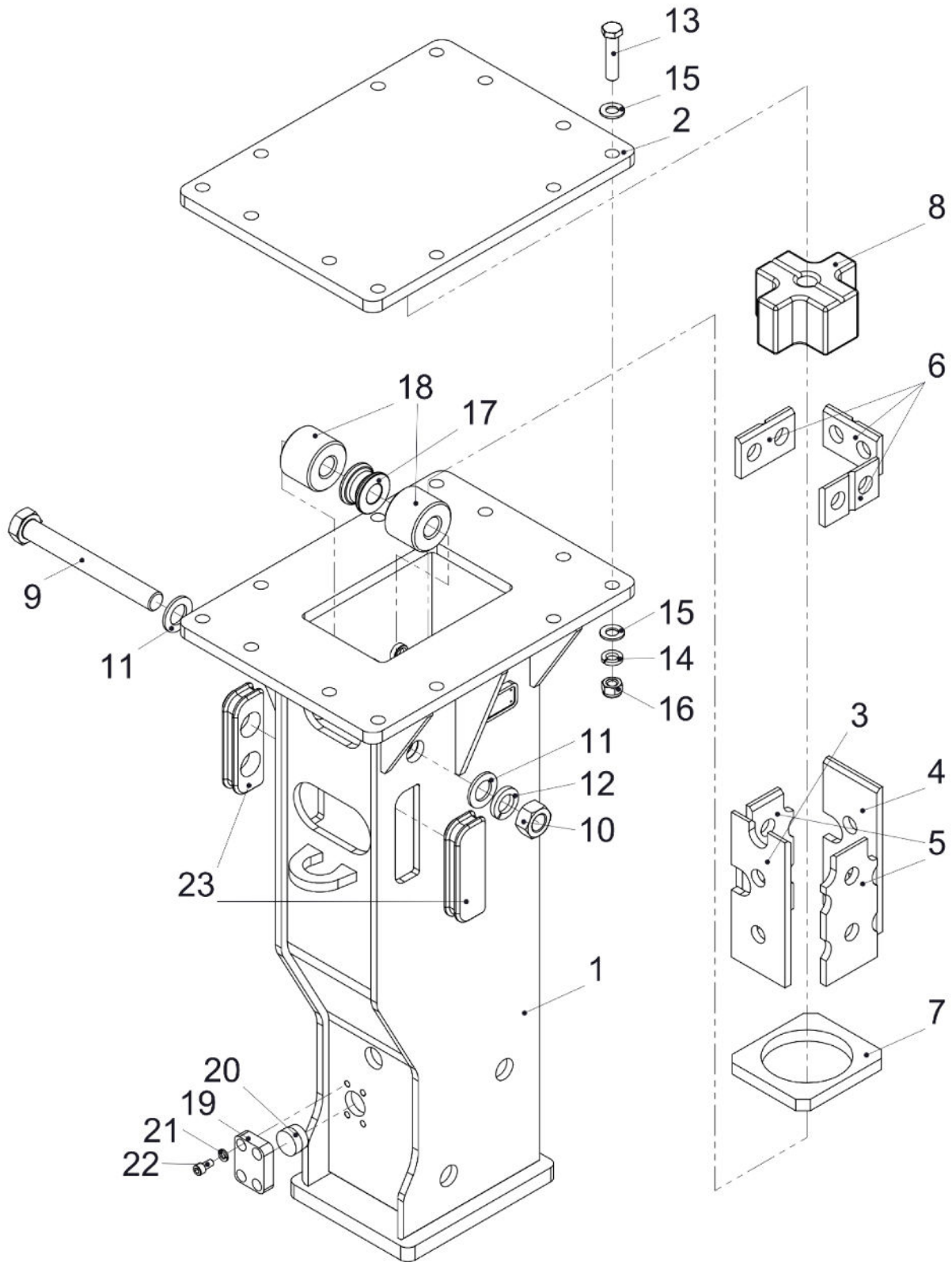

5.0 CHG9 Housing

NO.	PART NO.	PART NAME	QTY	REMARKS
	CHG0957000	HOUSING TOTAL ASSEMBLY	1	
1	CHG0957001	HOUSING WELD ASSEMBLY	1	
2	CHG0957002	TOP COVER PLATE	1	OPTION
3	CHG0955003	WEARING PLATE	1	
4	CHG0955018	WEARING PLATE	1	
5	CHG0955004	WEARING PLATE	2	
6	CHG0955005	WEARING PLATE	3	
7	CHG0955002	TOP BUFFER	1	
8	CHG0955006	SIDE BUFFER	1	
9	CHG0955007	SIDE JOINT BOLT	1	
10	CHG0955012	HEX BOLT	1	
11	CHG0955010	PLAIN WASHER	2	
12	CHG0955011	SPRING WASHER	1	
13	CHG0955013	HEX. BOLT	12	
14	CHG0252009	SPRING WASHER	12	
15	CHG0252008	PLAIN WASHER	24	
16	CHG0252010	NYLON LOCK NUT	12	
17	CHG0955008	SIDEWASHER	1	
18	CHG0955009	SIDE BUFFER	2	
19	CHG0955019	TOOL PIN COVER	1	
20	CHG0955020	TOOL PIN STOP	1	
21	CHG0955021	SPRING WASHER	4	
22	CHG0955022	SOCKET BOLT	4	
23	CHG0957003	SIDE RUBBER	2	



CHG Series Gas Fired Hammers Limited Warranty

Connect Work Tools offers this warranty to owners of new Connect Work Tools equipment that, after delivery and placement into service by the first user, the authorized Connect Work Tools Distributor in whose service area the product is operated will repair or replace any part that fails because of defects in material or workmanship. Connect Work Tools warranty covers new or original equipment only. This warranty does not apply to used equipment, that has been in service beyond the new product warranty period.

STANDARD RATE SCHEDULE

The following rate schedule is in effect and will be applied when evaluating and processing all related requests.

Warranty Coverage:

CHG2 - CHG3 - CHG6 - CHG7 - CHG9 - CHG10 - CHG15

Months	Parts	Labor
0-12	No Change	No Change

Connect Work Tools guarantees that the product shall be free from defects in materials or workmanship for a period of 12 months of installation date or 18 months from invoice date, whatever comes first.

Before submitting a warranty claim, make sure the attachment qualifies and meets the guidelines for warranty consideration.

Prior to performing a warranty action and submitting Connect Work Tools warranty claim the distributor must obtain pre-approval and a warranty claim number.

Contact the Connect Work Tools Customer Service Department at: 920-238-6657 or Email: service@connectworktools.com

CONNECTTM
WORK TOOLS

920.238.6657

www.connectworktools.com

