

Gas Fired Breakers

Model: CHG6

Parts Manual CHG-Series



Part #CHGE00012

Connect Work Tools - www.connectworktools.com - 920.238.6657

Table of Contents

Contact Information	4
1.0 Equipment Identification	
1.1 Location of Serial Number	5
1.2 Owner's Record of Equipment	5
2.0 Decals	6
3.0 Base Plates	8
4.0 CHG6 Hammer	
4.1 Hammer	10
4.2 Back Head Sub Assembly	11
4.3 Cylinder Sub Assembly	12
4.4 Front Head Sub Assembly	14
4.5 Side Rod Set	15
5.0 CHG6 Housing	16
5.1 Box Housing	16

Contact Information



Connect Work Tools
155 Main Street
Superior, WI 54880

E-mail: info@connectworktools.com
Main Phone: 920-238-6657
Fax: 715-395-3703

Contact your Connect Work Tools Representative or the Connect Work Tools Parts Department for replacement manuals. Inquiries regarding the content of this manual must include the release date shown below.

Information in this manual is subject to change without advance notice.

Table 1.1 About this manual

Document ID No.	CHGE00012
Type	Parts
Release Date	January 2024
Product Name	Gas fired Breakers
Series	CHG
Applicable Models	CHGE
Years of Manufacture	2024 & above

1.0 Equipment Identification

1.1 Location of the Serial Number Decal

Models: CHG2/CHG3/CHG6/CHG7/
CHG9/ CHG10/CHG15

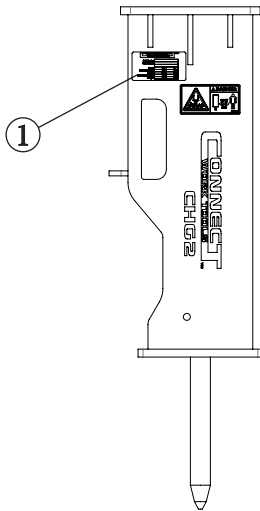

The Serial Equipment Identification Decal is affixed to the side of the housing box. It provides the following information:

- Serial Number
- Model
- Part Number
- Weight
- Operating Pressure
- Oil Flow
- Carrier Relief Pressure
- Nitrogen

****Note: Prior to ordering parts, it's important to confirm your model and serial number**

CONNECT™ WORK TOOLS			
Serial Number:	<input type="text"/>		
Model Number:	<input type="text"/>		
Weight:	<input type="text"/>	kg	<input type="text"/>
Operating Pressure:	<input type="text"/>	bar	<input type="text"/>
Oil Flow:	<input type="text"/>	l/min	<input type="text"/>
Carrier Relief Pressure:	<input type="text"/>	bar	<input type="text"/>
Nitrogen:	<input type="text"/>	bar	<input type="text"/>

1.2 Owner's Record of the Equipment

Record the Model and Serial Number from the Serial Equipment Identification Tag to the space provided below. Indicate the date in which the Connect Work Tools equipment was placed into service.

Model CHG2: CHG2
 Model CHG3: CHG3
 Model CHG6: CHG6
 Model CHG7: CHG7
 Model CHG9: CHG9
 Model CHG10: CHG10
 Model CHG15: CHG15

Serial Number: _____

In Service Date: _____

Your Connect Work Tools representative requires this information to better assist you with questions regarding parts, warranty, operation, maintenance, or repair.

Your equipment must be registered by your local Distributor at the time of sale.

Product Registration Date: _____

2.0 Decals

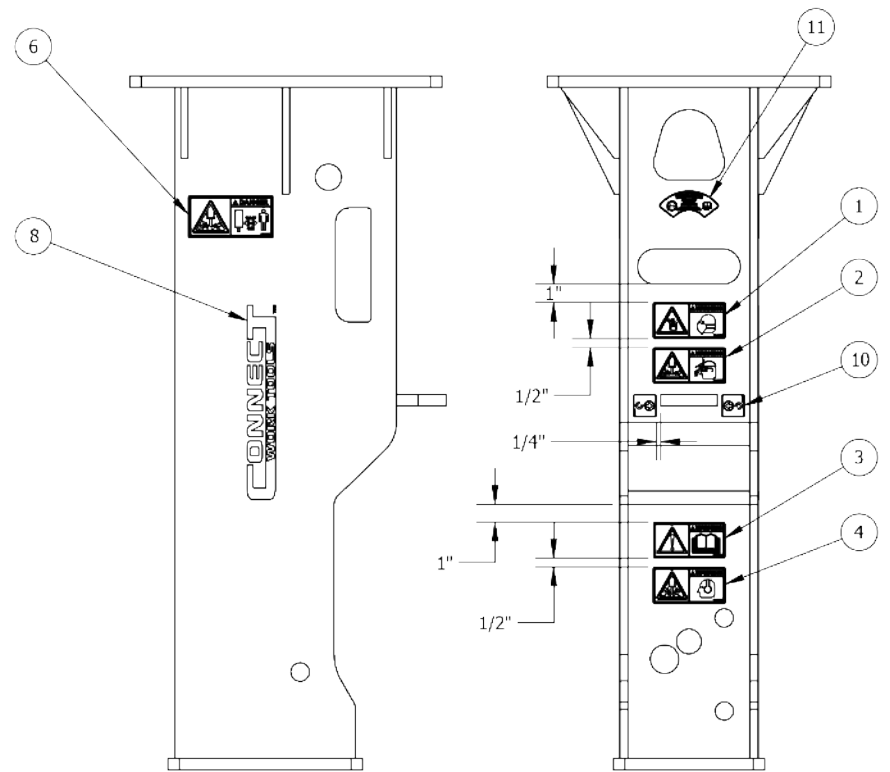
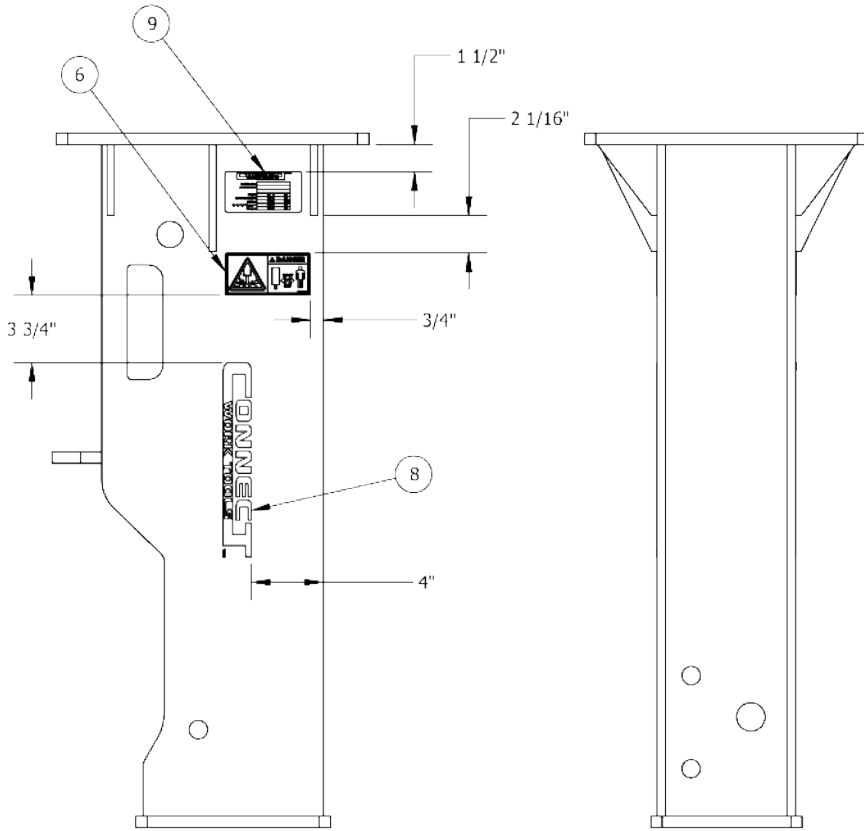

2.0 Decals

All decals pictured are included in decal kits (with exception of No. 10)

2.1 Standard Decals



1. Part Number 16-00076 - Decal Warning Dust



2. Part Number 16-00077 - Decal Warning Flying Objects



3. Part Number 16-00078 - Decal Warning Read Manual



4. Part Number 16-00079 - Decal Warning Noise



5. Part Number 16-00080 - Decal Grease Point



6. Part Number 16-00086 - Decal Warning Safe Distance



7. Part Number CHG00005 - Decal CHG6



8. Part Number CHE00166 - Decal Connect Logo 11" - CHG2/CHG3/CHG6/CHG7
Part Number CHE00109 - Decal Connect Logo 18" - CHG9/CHG10/CHG15



9. Part Number CHE00127 - Decal SN Plate (Not included in Decal Kit)



10. Part Number 16-00082 - Decal Lift Point



11. Part Number CHE00111 - Decal Warning Nitrogen

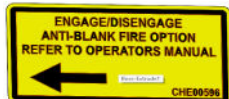

12. Part Number CHE00596 - Decal Warning Anti-Blank Fire

Fig. 2.1 Standard Decals

3.0 Base Plates

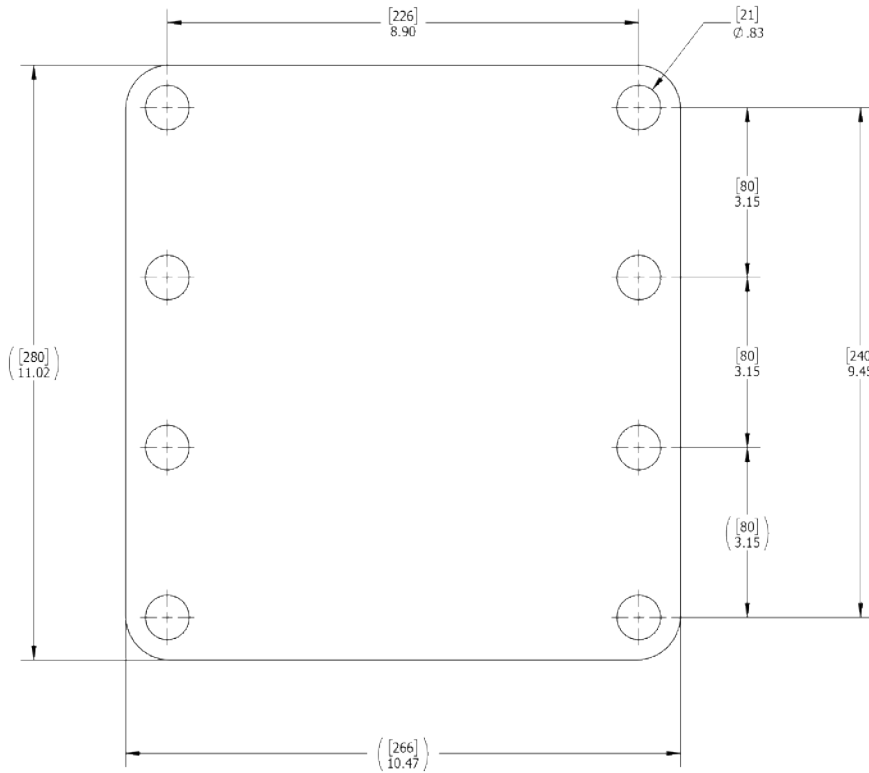

CHGE00101 - CHG2 - BASE PLATE

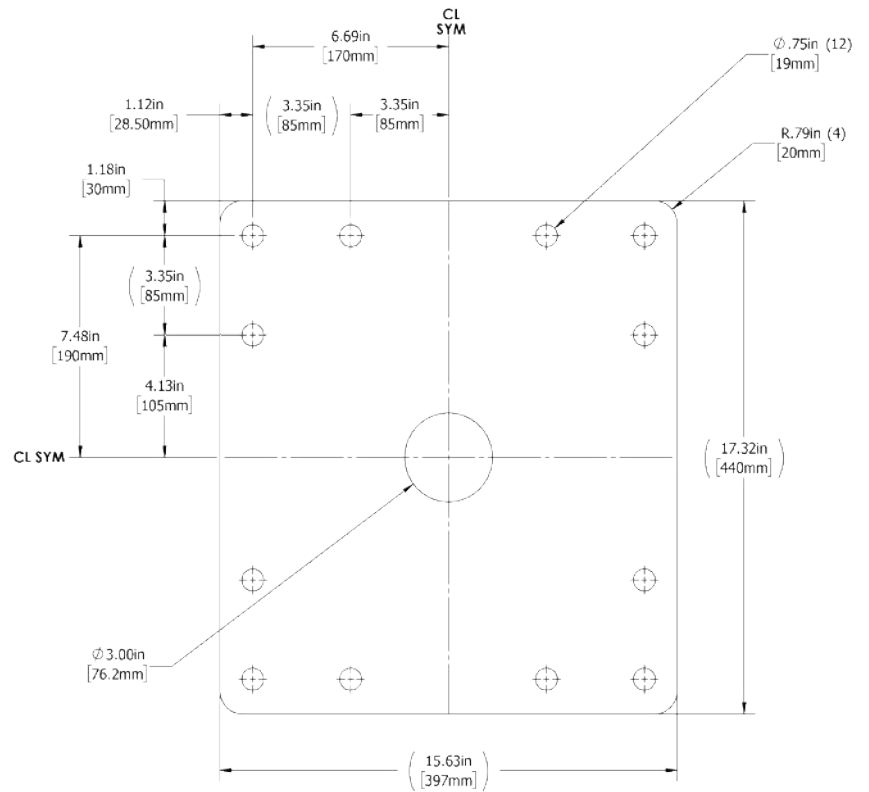

CHE00100 - CHG3/CHG6/CHG7 - BASE PLATE

3.0 Base Plates

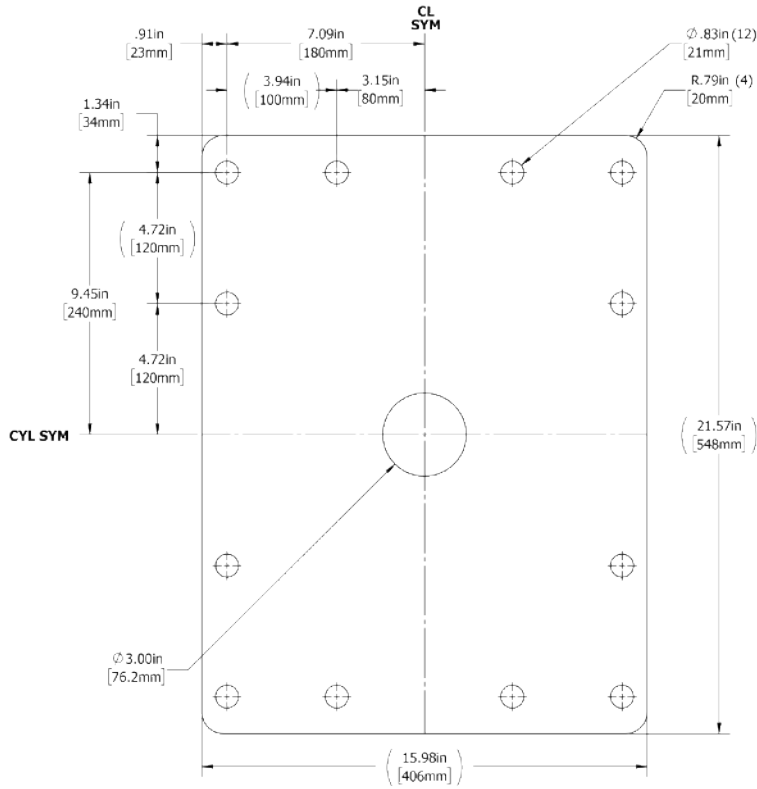

CHE00101 - CHG9/CHG10 - BASE PLATE

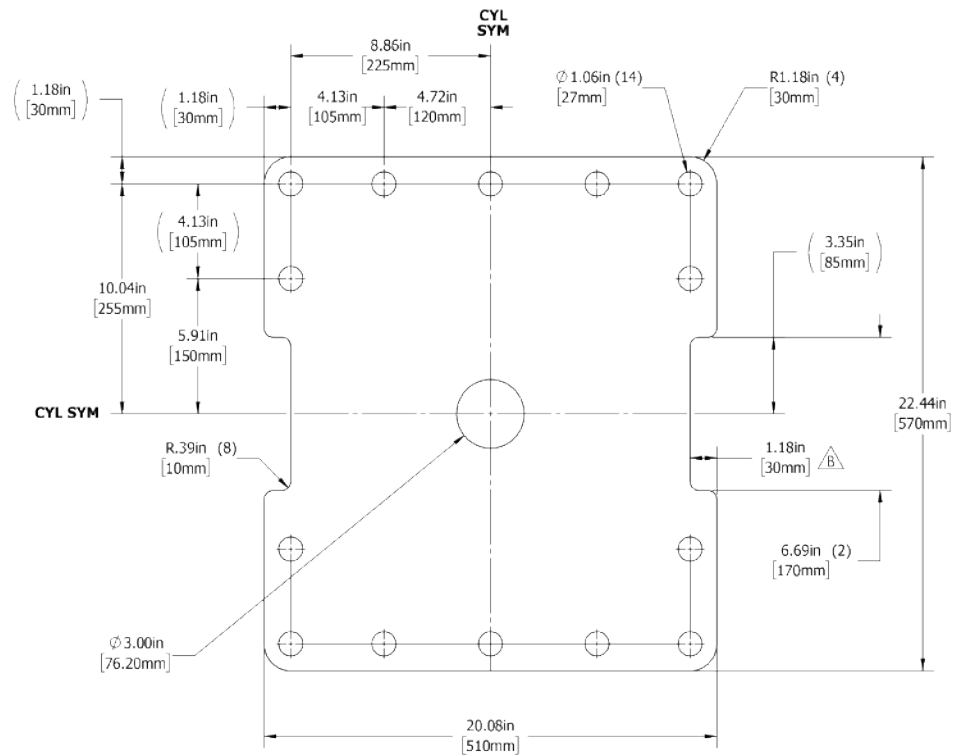

CHE00103 - CHG15 - BASE PLATE

4.0 CHG6 Hammer

4-1. Hammer

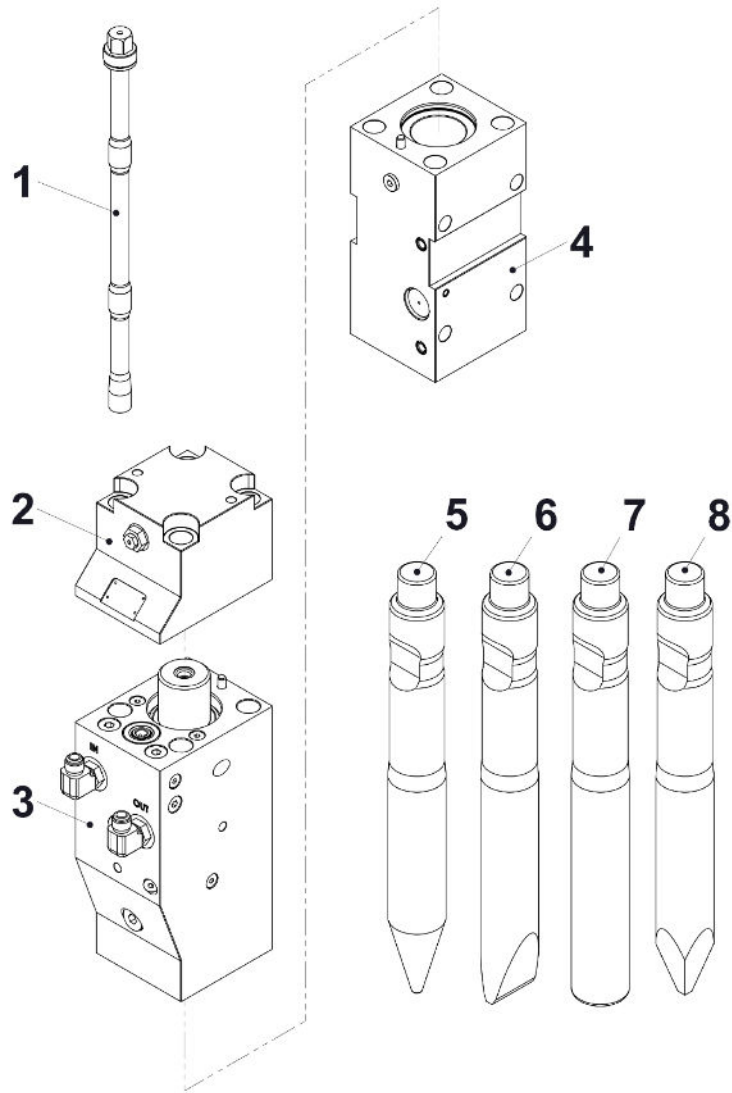

NO.	PART NO.	PART NAME	QTY	REMARKS
	CHG0615000	HAMMER TOTAL ASSEMBLY	1	
1	CHG0616000	BACK HEAD SUB ASSEMBLY	1	
2	CHG0617000	CYLINDER SUB ASSEMBLY	1	
3	CHG0618000	FRONT HEAD SUB ASSEMBLY	1	
4	CHG0619000	SIDE ROD SET	4	
5	CHG0620000	CHG6 CHISEL	1	
6	CHG0621000	CHG6 MOIL	1	
7	CHG0622000	CHG6 CONE	1	
8	CHG0623000	CHG6 BLUNT	1	
	CHG0624000	CHG6 SEAL KIT	1	

4.0 CHG6 Hammer

4-2. Back Head Sub Assembly

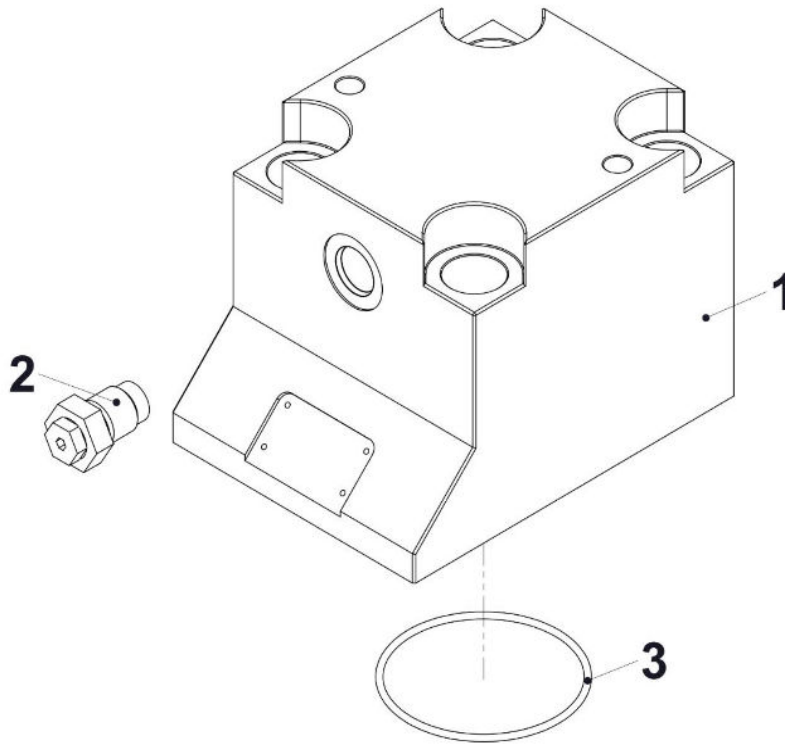

NO.	PART NO.	PART NAME	QTY	REMARKS
	CHG0616000	BACK HEAD SUB ASSEMBLY	1	
1	CHG0616001	CHG6 BACK HEAD	1	
2	CHG0616002	O-RING	1	PART OF SEAL KIT
3	CHG0616003	GAS CHARGING VALVE ASSEMBLY	1	

4.0 CHG6 Hammer

4-3. Cylinder Sub Assembly

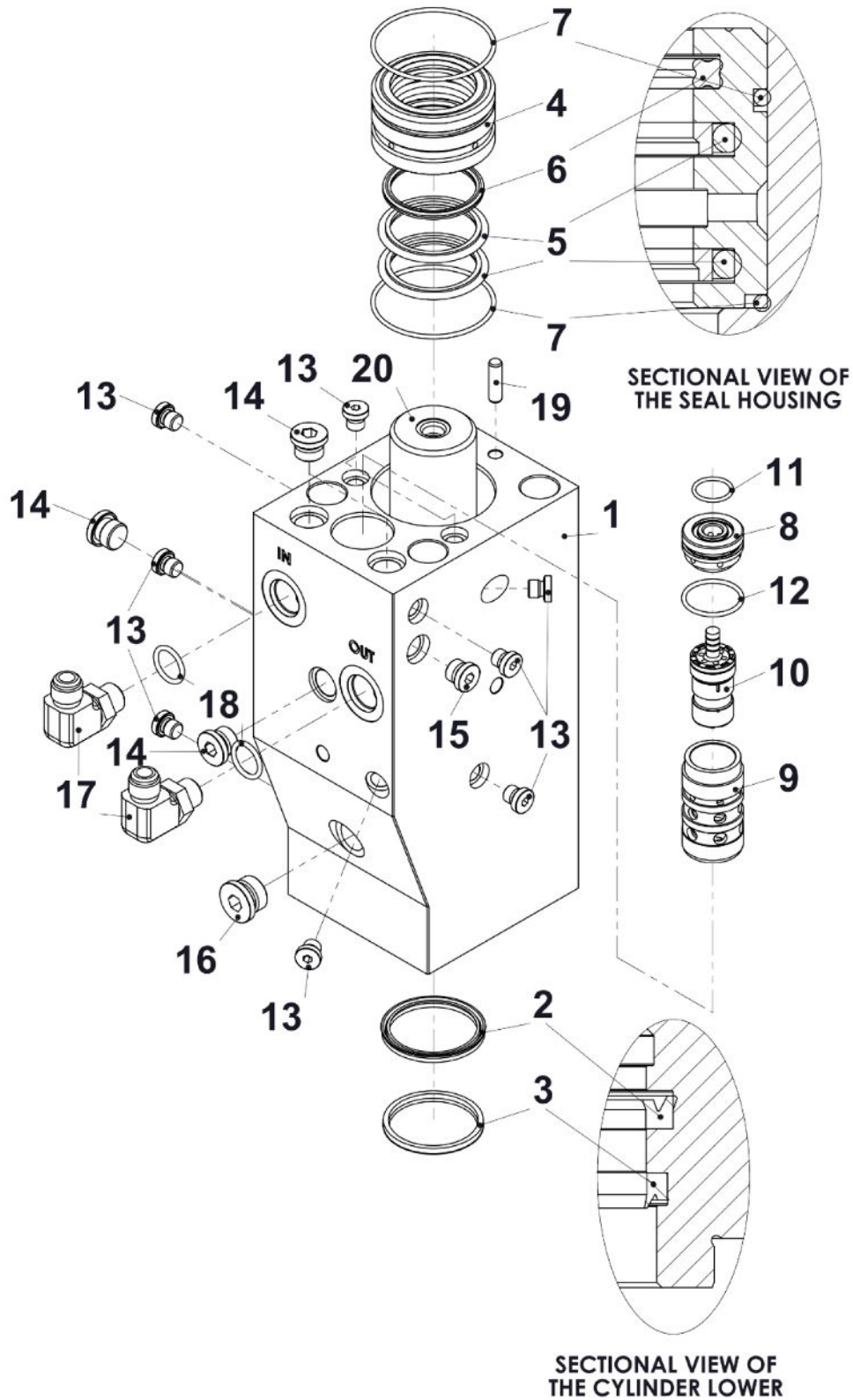

4.0 CHG6 Hammer

NO.	PART NO.	PART NAME	QTY	REMARKS
	CHG0617000	CYLINDER SUB ASSEMBLY	1	
1	CHG0617001	CHG6 CYLINDER	1	
2	CHG0617002	U-PACKING	1	PART OF SEAL KIT
3	CHG0617003	WIPER	1	PART OF SEAL KIT
4	CHG0617004	SEAL HOUSING	1	
5	CHG0617005	STEP SEAL	2	PART OF SEAL KIT
6	CHG0617006	QUAD RING	1	PART OF SEAL KIT
7	CHG0617007	O-RING	2	PART OF SEAL KIT
8	CHG0617008	OPER. VALVE COVER	1	
9	CHG0617009	OPER. VALVE GUIDE	1	
10	CHG0617010	OPER. VALVE SPOOL	1	
11	CHG0617011	O-RING	1	PART OF SEAL KIT
12	CHG0617012	O-RING	1	PART OF SEAL KIT
13	CHG0617013	SOCKET PLUG	9	
14	CHG0617014	SOCKET PLUG	4	
15	CHG0617015	SOCKET PLUG	1	
16	CHG0617016	SOCKET PLUG	1	
17	CHG0617017	ADAPTER	2	PF 3/4" - OPTION
18	CHG0617018	O-RING	1	OPTION
19	CHG0617019	GUIDE PIN	1	
20	CHG0617020	PISTON	1	

4.0 CHG6 Hammer

4-4. Front Head Sub Assembly

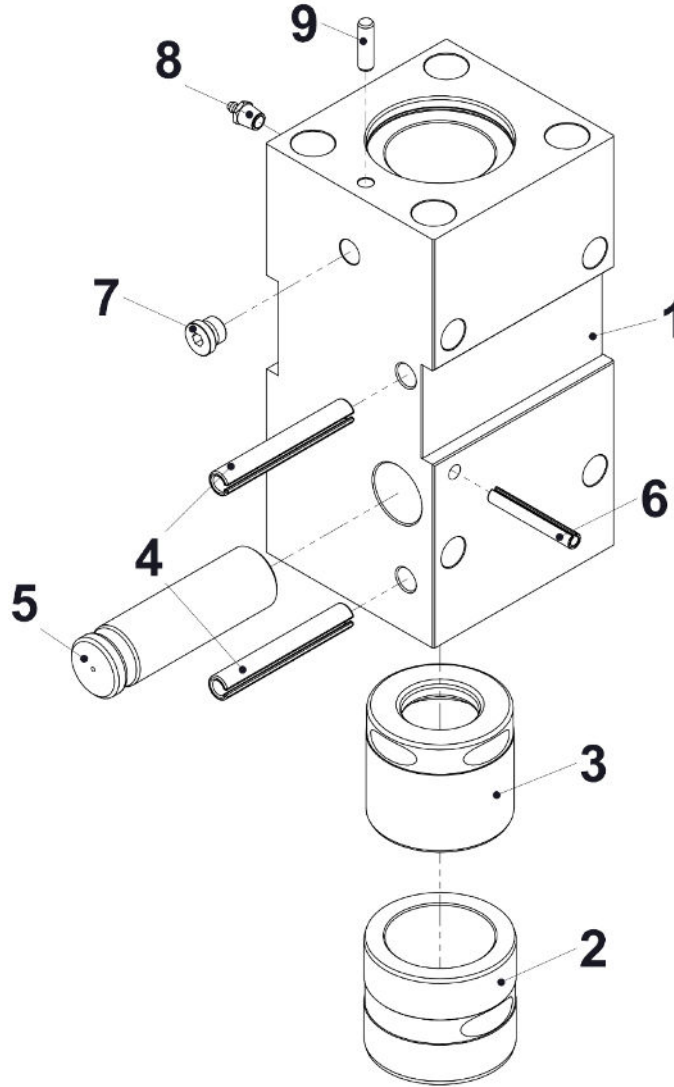

NO.	PART NO.	PART NAME	QTY	REMARKS
	CHG0618000	FRONT HEAD SUB ASSEMBLY	1	
1	CHG0618001	CHG6 FRONT HEAD	1	
2	CHG0618002	CHG6 UPPER BUSHING	1	
3	CHG0618003	CHG6 TOOL BUSHING	1	
4	CHG0618004	SPRING PIN	2	
5	CHG0618005	TOOL PIN	1	
6	CHG0618006	SPRING PIN	1	
7	CHG0618007	SOCKET PLUG	1	
8	CHG0618008	GREASE NIPPLE	1	
9	CHG0618009	GUIDE PIN	1	

4.0 CHG6 Hammer

4-5. Side Rod Set

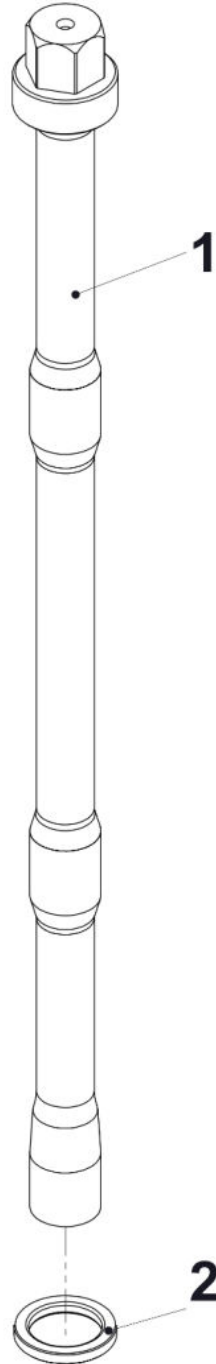

NO.	PART NO.	PART NAME	QTY	REMARKS
	CHG0619000	SIDE ROD SET	4	
1	CHG0619001	CHG6 SIDE ROD	4	
2	CHG0619002	CHG6 SIDE ROD NUT	4	

5.0 CHG6 Housing

5-1. Box Housing

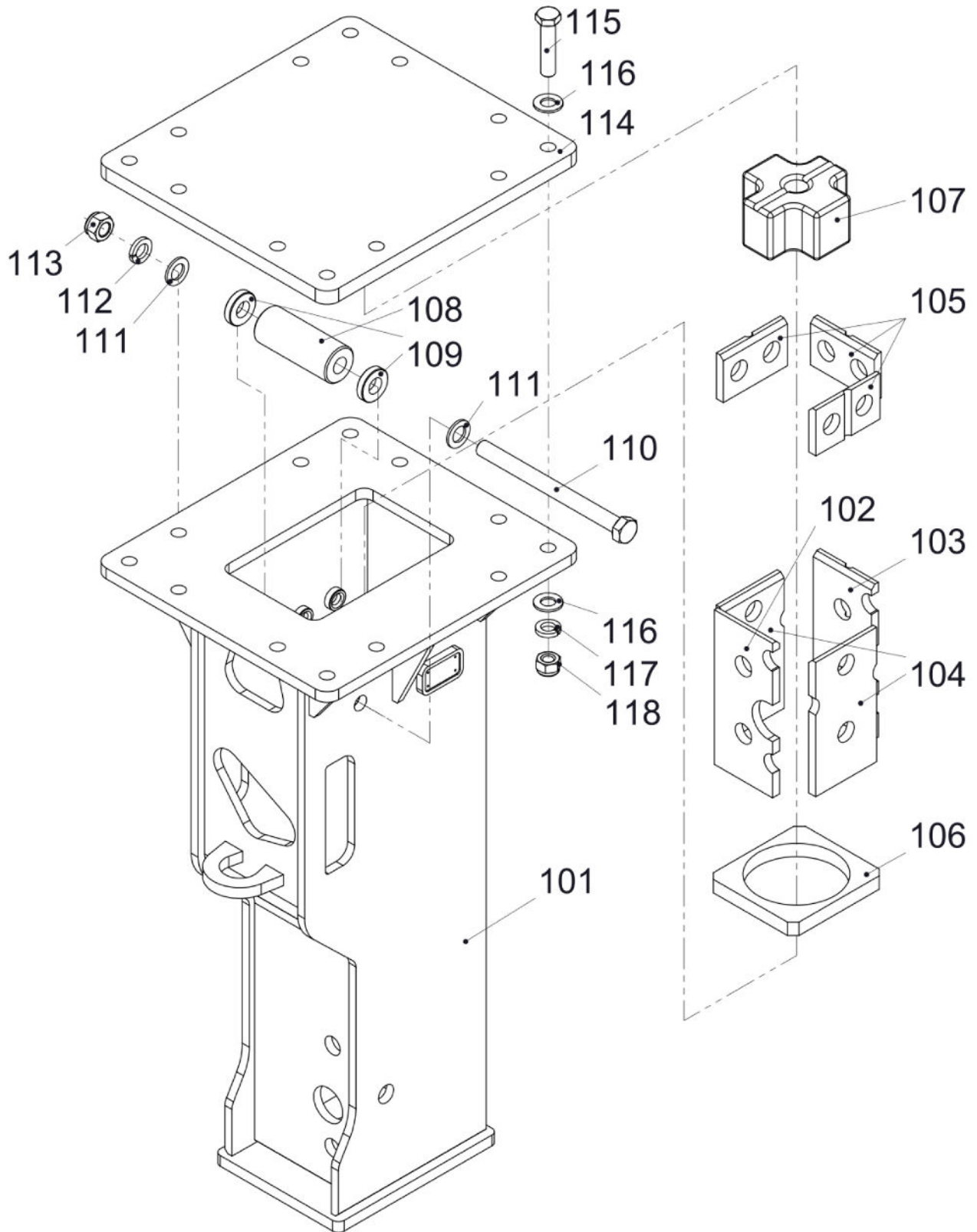

5.0 CHG6 Housing

NO.	PART NO.	PART NAME	QTY	REMARKS
	CHG0654000	HOUSING TOTAL ASSEMBLY	1	
101	CHG0654001	HOUSING WELD ASSEMBLY	1	
102	CHG0654002	WEARING PLATE	1	
103	CHG0654003	WEARING PLATE	1	
104	CHG0654004	WEARING PLATE	2	
105	CHG0751006	WEARING PLATE	3	
106	CHG0751007	BASE BUFFER	1	
107	CHG0654005	TOP BUFFER	1	
108	CHG0751014	SIDE BUFFER	1	
109	CHG0654006	SIDE WASHER	2	
110	CHG0654007	HEX BOLT	1	
111	CHG0654008	PLAIN WASHER	2	
112	CHG0654009	SPRING WASHER	1	
113	CHG0654010	NYLON LOCK NUT	1	
114	CHG0654011	TOP COVER PLATE	1	OPTION
115	CHG0654012	HEX. BOLT	12	
116	CHG0654013	PLAIN WASHER	24	
117	CHG0654014	SPRING WASHER	12	
118	CHG0654015	NYLON LOCK NUT	12	



CHG Series Gas Fired Hammers Limited Warranty

Connect Work Tools offers this warranty to owners of new Connect Work Tools equipment that, after delivery and placement into service by the first user, the authorized Connect Work Tools Distributor in whose service area the product is operated will repair or replace any part that fails because of defects in material or workmanship. Connect Work Tools warranty covers new or original equipment only. This warranty does not apply to used equipment, that has been in service beyond the new product warranty period.

STANDARD RATE SCHEDULE

The following rate schedule is in effect and will be applied when evaluating and processing all related requests.

Warranty Coverage:

CHG2 - CHG3 - CHG6 - CHG7 - CHG9 - CHG10 - CHG15

Months	Parts	Labor
0-12	No Change	No Change

Connect Work Tools guarantees that the product shall be free from defects in materials or workmanship for a period of 12 months of installation date or 18 months from invoice date, whatever comes first.

Before submitting a warranty claim, make sure the attachment qualifies and meets the guidelines for warranty consideration.

Prior to performing a warranty action and submitting Connect Work Tools warranty claim the distributor must obtain pre-approval and a warranty claim number.

Contact the Connect Work Tools Customer Service Department at: 920-238-6657 or Email: service@connectworktools.com

CONNECTTM
WORK TOOLS

920.238.6657

www.connectworktools.com

