

# Gas Fired Breakers

Model: CHG15

## Parts Manual CHG-Series



Part #CHGE00016



Connect Work Tools - [www.connectworktools.com](http://www.connectworktools.com) - 920.238.6657



---

---

# Table of Contents

Contact Information .....	4
1.0 Equipment Identification	
1.1 Location of Serial Number .....	5
1.2 Owner's Record of Equipment .....	5
2.0 Decals .....	6
3.0 Base Plates .....	8
4.0 CHG15 Hammer	
4.1 Hammer .....	10
4.2 Back Head Sub Assembly .....	11
4.3 Cylinder Sub Assembly .....	12
4.4 Front Head Sub Assembly .....	14
4.5 Side Rod Set .....	15
5.0 CHG15 Housing	
5.1 Box Housing .....	16

## Contact Information



**Connect Work Tools**  
**155 Main Street**  
**Superior, WI 54880**

**E-mail: [info@connectworktools.com](mailto:info@connectworktools.com)**  
**Main Phone: 920-238-6657**  
**Fax: 715-395-3703**

Contact your Connect Work Tools Representative or the Connect Work Tools Parts Department for replacement manuals. Inquiries regarding the content of this manual must include the release date shown below.

**Information in this manual is subject to change without advance notice.**

**Table 1.1 About this manual**

Document ID No.	CHGE00016
Type	Parts
Release Date	January 2024
Product Name	Gas fired Breakers
Series	CHG
Applicable Models	CHGE
Years of Manufacture	2024 & above

# 1.0 Equipment Identification

## 1.1 Location of the Serial Number Decal

Models: CHG2/CHG3/CHG6/CHG7/  
CHG9/ CHG10/CHG15

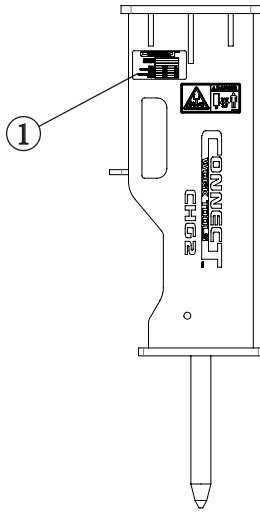

The Serial Equipment Identification Decal is affixed to the side of the housing box. It provides the following information:

- Serial Number
- Model
- Part Number
- Weight
- Operating Pressure
- Oil Flow
- Carrier Relief Pressure
- Nitrogen

**\*\*Note: Prior to ordering parts, it's important to confirm your model and serial number**

<b>CONNECT™ WORK TOOLS</b>			
Serial Number:			
Model Number:			
Weight:	kg		lb
Operating Pressure:	bar		psi
Oil Flow:	l/min		gpm
Carrier Relief Pressure:	bar		psi
Nitrogen:	bar		psi

## 1.2 Owner's Record of the Equipment

Record the Model and Serial Number from the Serial Equipment Identification Tag to the space provided below. Indicate the date in which the Connect Work Tools equipment was placed into service.

Model CHG2: CHG2  
 Model CHG3: CHG3  
 Model CHG6: CHG6  
 Model CHG7: CHG7  
 Model CHG9: CHG9  
 Model CHG10: CHG10  
 Model CHG15: CHG15

Serial Number: \_\_\_\_\_

In Service Date: \_\_\_\_\_

Your Connect Work Tools representative requires this information to better assist you with questions regarding parts, warranty, operation, maintenance, or repair.

Your equipment must be registered by your local Distributor at the time of sale.

Product Registration Date: \_\_\_\_\_

## 2.0 Decals

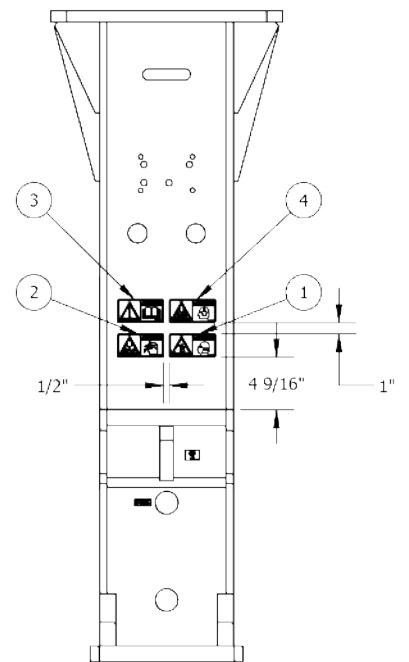
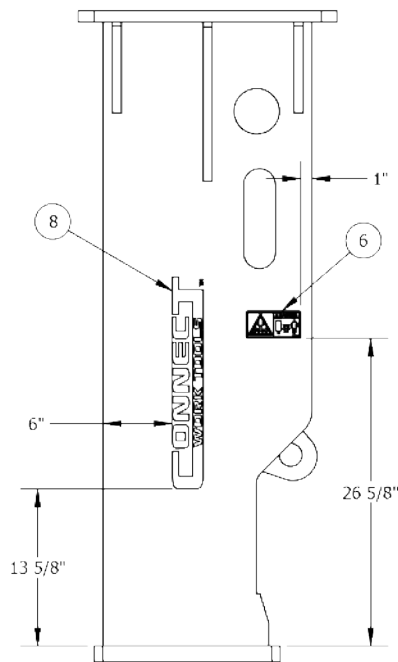
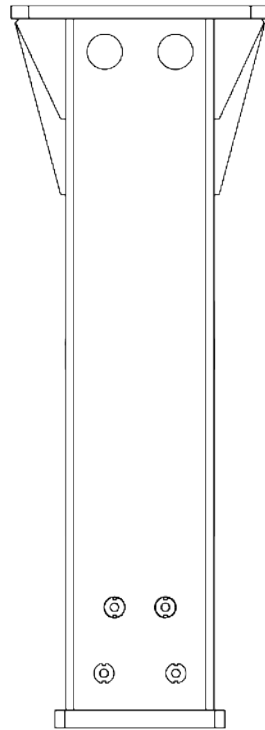
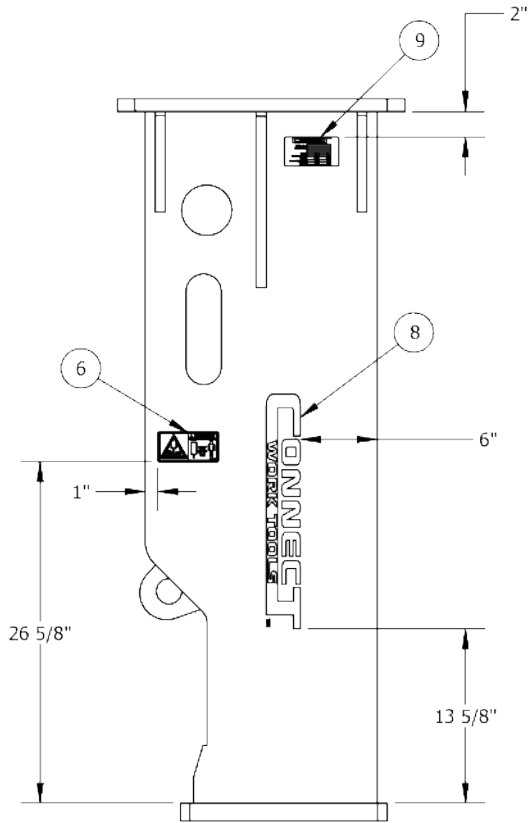

## 2.0 Decals

All decals pictured are included in decal kits (with exception of No. 10)

### 2.1 Standard Decals



1. Part Number 16-00076 - Decal Warning Dust



2. Part Number 16-00077 - Decal Warning Flying Objects



3. Part Number 16-00078 - Decal Warning Read Manual



4. Part Number 16-00079 - Decal Warning Noise



5. Part Number 16-00080 - Decal Grease Point



6. Part Number 16-00086 - Decal Warning Safe Distance



7. Part Number CHG00009 - Decal CHG15



8. Part Number CHE00166 - Decal Connect Logo 11" - CHG2/CHG3/CHG6/CHG7  
Part Number CHE00109 - Decal Connect Logo 18" - CHG9/CHG10/CHG15



9. Part Number CHE00127 - Decal SN Plate (Not included in Decal Kit)



10. Part Number 16-00082 - Decal Lift Point



11. Part Number CHE00111 - Decal Warning Nitrogen



12. Part Number CHE00596 - Decal Warning Anti-Blank Fire

Fig. 2.1 Standard Decals

## 3.0 Base Plates

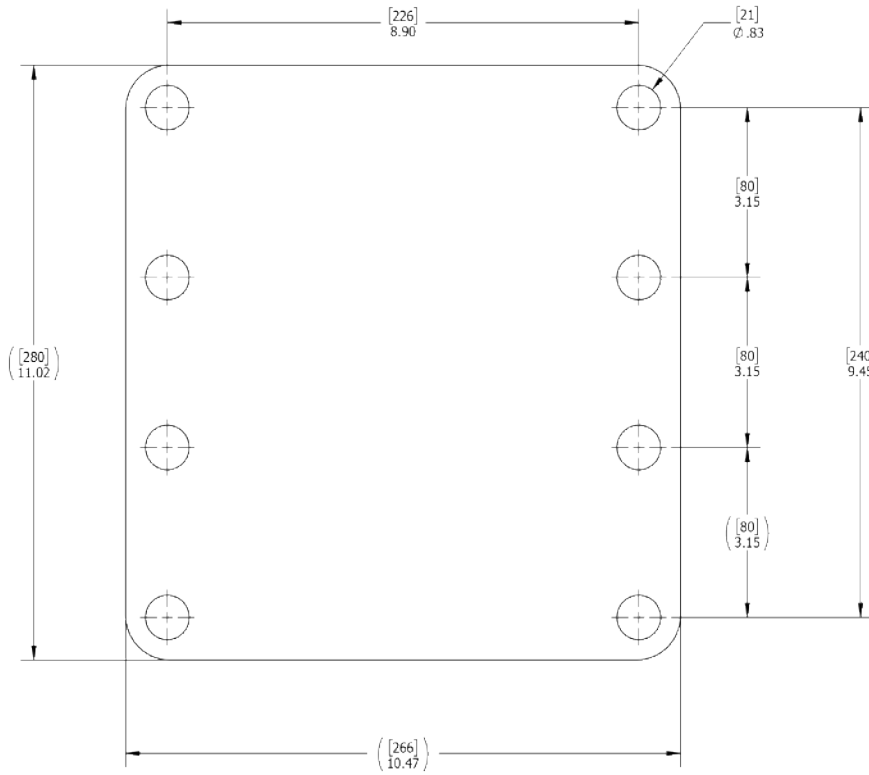

CHGE00101 - CHG2 - BASE PLATE

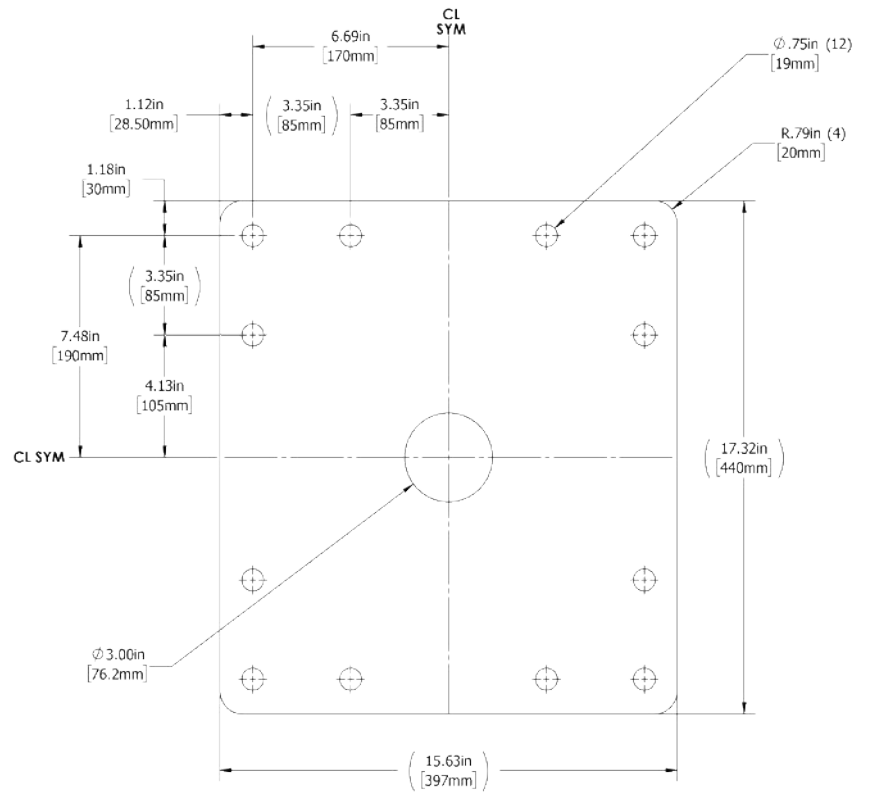

CHE00100 - CHG3/CHG6/CHG7 - BASE PLATE





## 4.0 CHG15 Hammer

### 4-1. Hammer

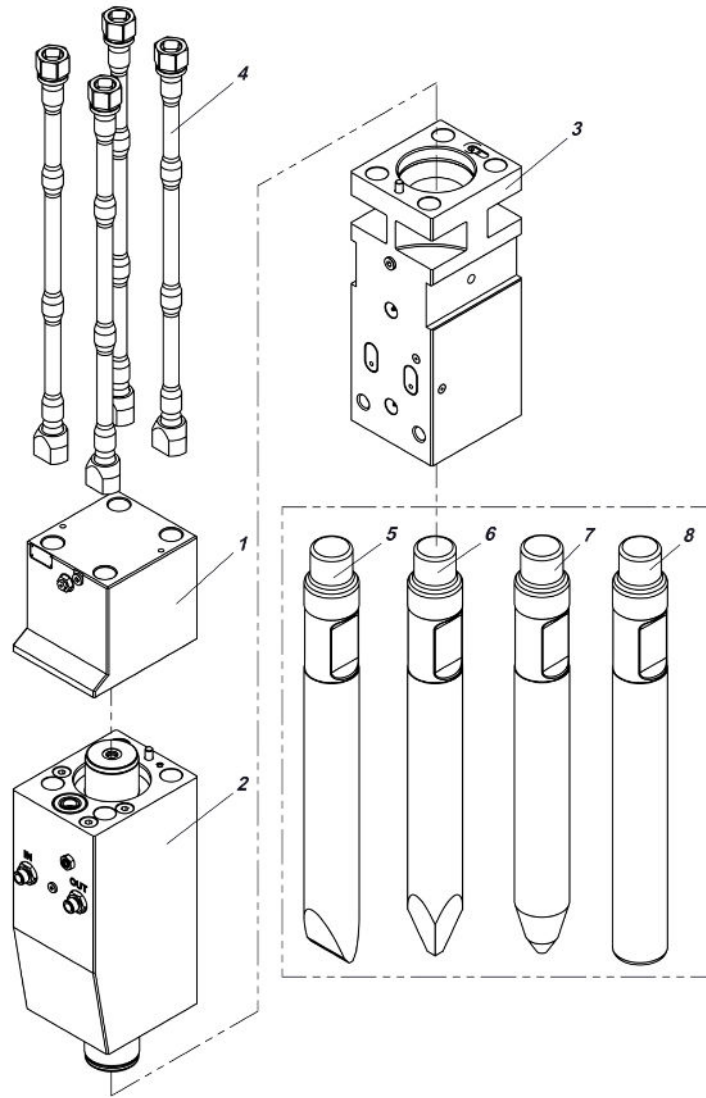

NO.	PART NO.	PART NAME	QTY	REMARKS
	CHG1500000	<b>HAMMER TOTAL ASSEMBLY</b>	1	
1	CHG1501000	<b>BACK HEAD SUB ASSEMBLY</b>	1	
2	CHG1502000	<b>CYLINDER SUB ASSEMBLY</b>	1	
3	CHG1503000	<b>FRONT HEAD SUB ASSEMBLY</b>	1	
4	CHG1504000	<b>SIDE ROD SET</b>	4	
5	CHG1505000	CHG15 CHISEL	1	
6	CHG1506000	CHG15 MOIL	1	
7	CHG1507000	CHG15 CONE	1	
8	CHG1508000	CHG15 BLUNT	1	
	CHG1510000	SEAL KIT	1	

## 4.0 CHG15 Hammer

### 4-2. Back Head Sub Assembly

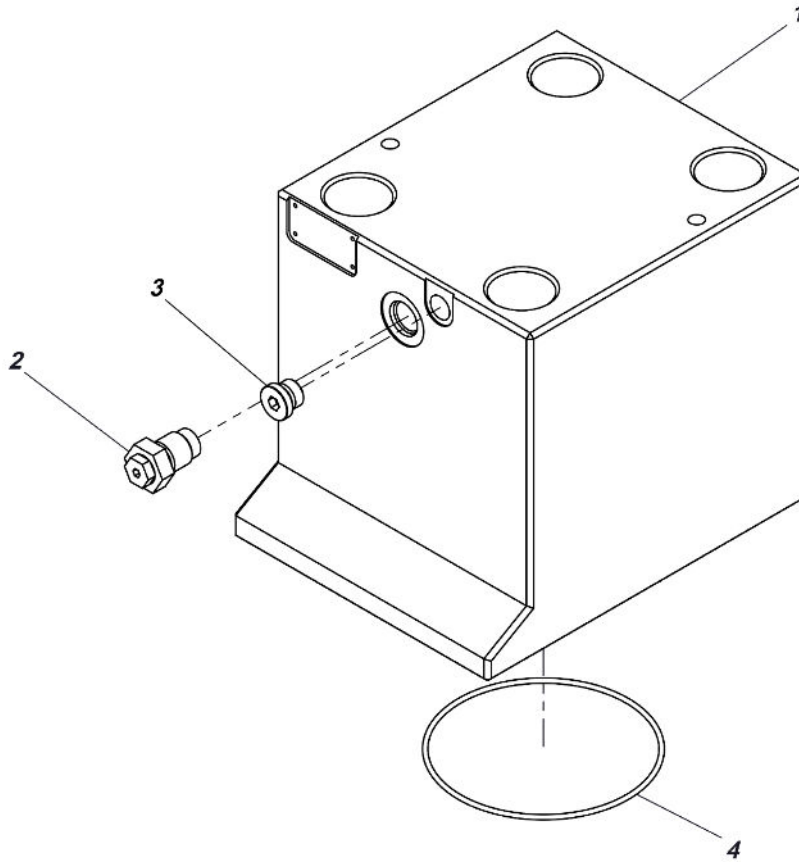

NO.	PART NO.	PART NAME	QTY	REMARKS
	CHG1501000	<b>BACK HEAD SUB ASSEMBLY</b>	1	
1	CHG1501001	CHG15 BACK HEAD	1	
2	CHG0201003	GAS CHARGING VALVE ASSEMBLY	1	
3	CHG0721004	SOCKET PLUG	1	
4	CHG1501004	O-RING	1	PART OF SEAL KIT

## 4.0 CHG15 Hammer

### 4-3. Cylinder Sub Assembly

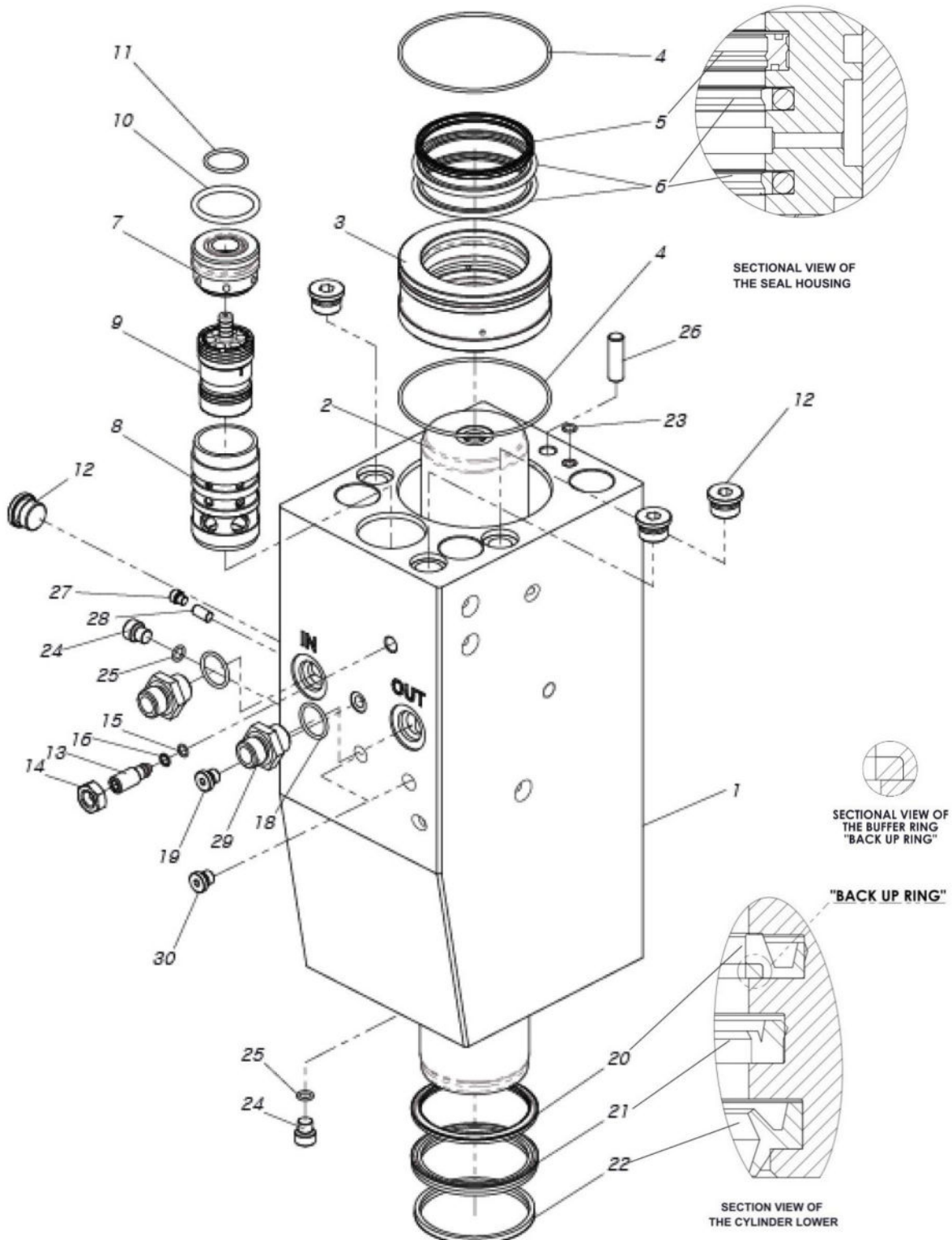

## 4.0 CHG15 Hammer

NO.	PART NO.	PART NAME	QTY	REMARKS
	CHG1502000	<b>CYLINDER SUB ASSEMBLY</b>		
1	CHG1502001	CHG15 CYLINDER	1	
2	CHG1502002	PISTON	1	
3	CHG1502003	SEAL HOUSING	1	
4	CHG1501004	O-RING	2	PART OF SEAL KIT
5	CHG1502005	GAS SEAL	1	PART OF SEAL KIT
6	CHG1502006	STEP SEAL	2	PART OF SEAL KIT
7	CHG1502007	SPOOL COVER	1	
8	CHG1502008	VALVE SPOOL GUIDE	1	
9	CHG1502009	SPOOL	1	
10	CHG1502010	O-RING	1	PART OF SEAL KIT
11	CHG0202010	O-RING	1	PART OF SEAL KIT
12	CHG0602014	SOCKET PLUG	4	
13	CHG1502013	ADJUST BOLT	1	
14	CHG1502014	HEX. NUT	1	
15	CHG1502015	O-RING	1	PART OF SEAL KIT
16	CHG1502016	BACK UP RING	1	PART OF SEAL KIT
18	CHG0722026	O-RING	2	OPTION
19	CHG0202011	SOCKET PLUG	1	
20	CHG1502020	BUFFER RING	1	PART OF SEAL KIT
21	CHG1502021	U-PACKING	1	PART OF SEAL KIT
22	CHG1502022	WIPER	1	PART OF SEAL KIT
23	CHG0722023	O-RING	1	PART OF SEAL KIT
24	CHG1502028	SOCKET PLUG	2	
25	CHG1502029	O-RING	2	PART OF SEAL KIT
26	CHG1502030	GUIDE PIN	1	
27	CHG1502031	HEX. PLUG	1	
28	CHG1502032	ASO PIN	1	OPTION
29	CHG1502033	ADAPTER	2	PF 3/4" - OPTION
30	CHG0721004	SOCKET PLUG	2	

## 4.0 CHG15 Hammer

### 4-4. Front Head Sub Assembly

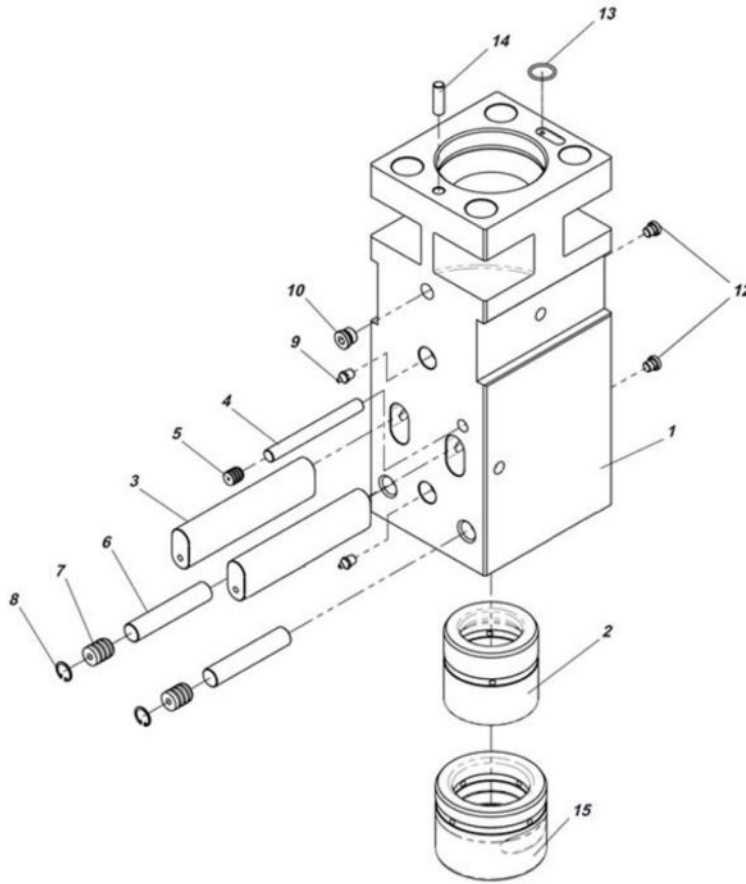

NO.	PART NO.	PART NAME	QTY	REMARKS
	CHG1503000	<b>FRONT HEAD SUB ASSEMBLY</b>	1	
1	CHG1503001	FRONT HEAD	1	
2	CHG1503002	UPPER BUSHING	1	
3	CHG1503017	TOOL PIN	2	
4	CHG1503004	BUSHING PIN	1	
5	CHG1503005	RUBBER PLUG	1	
6	CHG1503006	BUSHING PIN	2	
7	CHG1503007	RUBBER PLUG	2	
8	CHG1503008	SNAP RING	2	
9	CHG0203004	GREASE NIPPLE	2	
10	CHG0722016	SOCKET PLUG	1	
12	CHG0202011	SOCKET PLUG	2	
13	CHG0922014	O-RING	1	PART OF SEAL KIT
14	CHG1502030	GUIDE PIN	1	
15	CHG1503015	TOOL BUSHING	1	

## 4.0 CHG15 Hammer

### 4-5. Side Rod Set

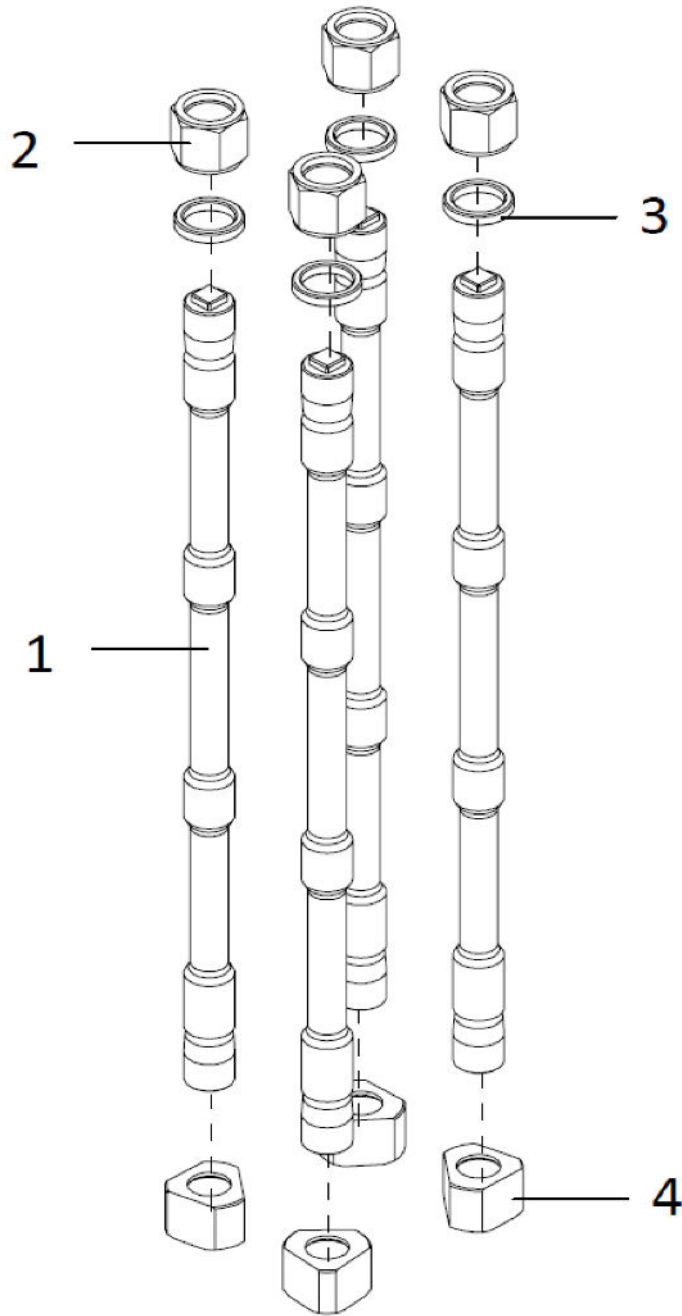

NO.	PART NO.	PART NAME	QTY	REMARKS
	CHG1504000	<b>SIDE ROD SET</b>	4	
1	CHG1504001	CHG15 SIDE ROD	4	
2	CHG1504002	SIDE ROD UPPER NUT	4	
3	CHG1504003	SIDE ROD WASHER	4	
4	CHG1504004	SIDE ROD LOWER NUT	4	

## 5.0 CHG15 Housing

### 5-1. Box Housing

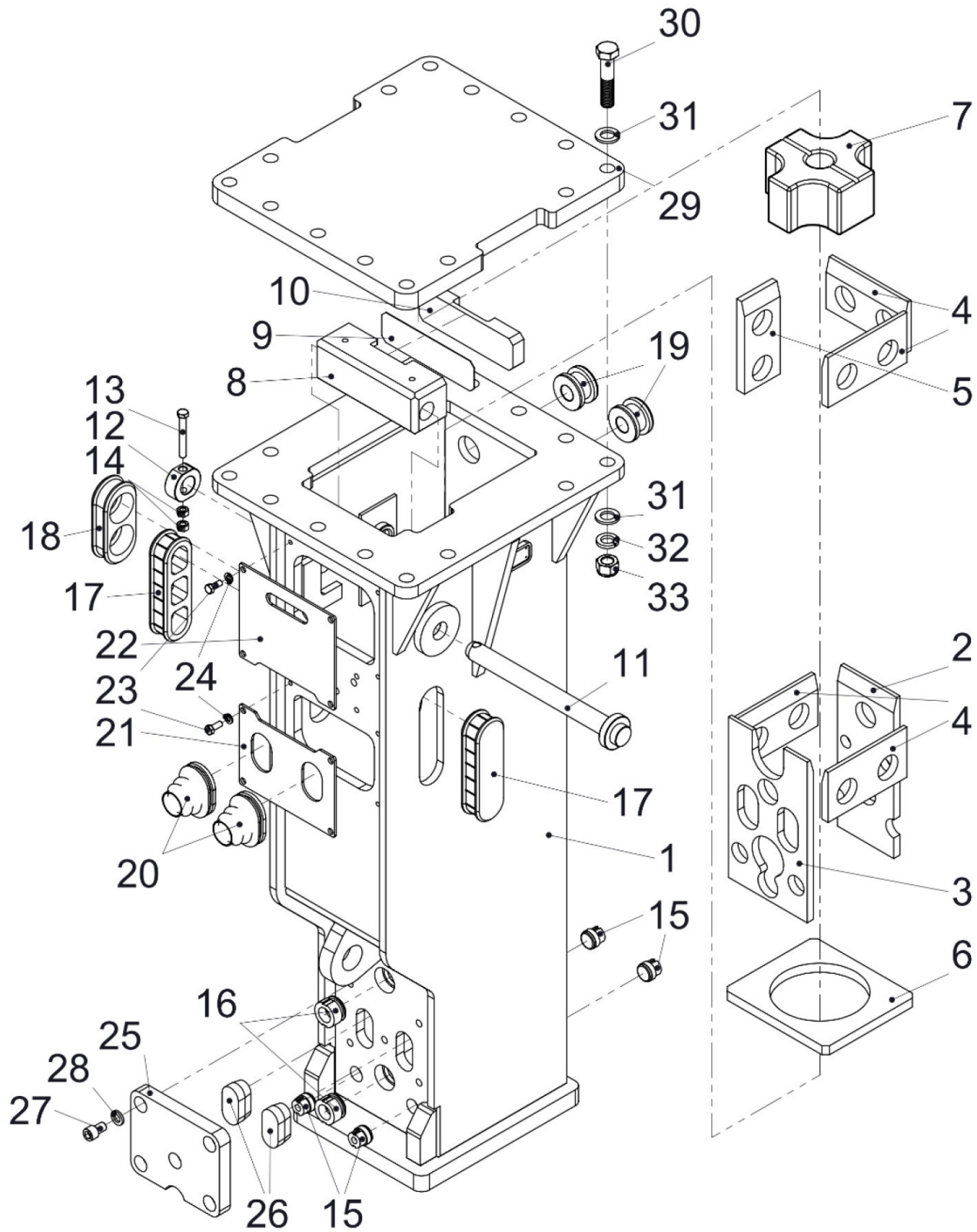



## 5.0 CHG15 Housing

NO.	PART NO.	PART NAME	QTY	REMARKS
	CHG1556000	<b>HOUSING TOTAL ASSEMBLY</b>	1	
1	CHG1556001	HOUSING WELD ASSEMBLY	1	
2	CHG1553005	WEARING PLATE	1	
3	CHG1553004	WEARING PLATE	1	
4	CHG1553002	WEARING PLATE	4	
5	CHG1553003	WEARING PLATE	1	
6	CHG1553006	BASE BUFFER	1	
7	CHG1553007	TOP BUFFER	1	
8	CHG1553030	FRONT BLOCK	1	
9	CHG1553032	SHIM PLATE	1	
10	CHG1553031	FRONT PLATE	1	
11	CHG1553034	PIN	1	
12	CHG1553014	STOPPER	1	
13	CHG1553016	HEX BOLT	1	
14	CHG1553019	HEX NUT	2	
15	CHG1553010	RUBBER PLUG	4	
16	CHG1553013	RUBBER GREASE	2	
17	CHG1553011	RUBBER PLUG	2	
18	CHG1553012	RUBBER PLUG	1	
19	CHG1553009	RUBBER PLUG	2	
20	CHG1553008	RUBBER (IN, OUT)	2	
21	CHG1553028	COVER PLATE- 1	1	
22	CHG1553029	COVER PLATE- 2	1	
23	CHG1553015	HEX. BOLT	8	
24	CHG1553024	SPRING WASHER	8	
25	CHG1553036	HOUSING TOOL PIN COVER	1	
26	CHG1553035	TOOL PIN COVER	2	
27	CHG1553038	SOCKET BOLT	5	
28	CHG1553037	SPRING WASHER	5	
29	CHG1556002	TOP COVER PLATE	1	OPTION
30	CHG1556003	HEX BOLT	14	
31	CHG1553023	PLAIN WASHER	28	
32	CHG1553026	SPRING WASHER	14	
33	CHG1553020	NYLON LOCK NUT	14	



## CHG Series Gas Fired Hammers Limited Warranty

Connect Work Tools offers this warranty to owners of new Connect Work Tools equipment that, after delivery and placement into service by the first user, the authorized Connect Work Tools Distributor in whose service area the product is operated will repair or replace any part that fails because of defects in material or workmanship. Connect Work Tools warranty covers new or original equipment only. This warranty does not apply to used equipment, that has been in service beyond the new product warranty period.

### STANDARD RATE SCHEDULE

The following rate schedule is in effect and will be applied when evaluating and processing all related requests.

#### Warranty Coverage:

**CHG2 - CHG3 - CHG6 - CHG7 - CHG9 - CHG10 - CHG15**

Months	Parts	Labor
0-12	No Change	No Change

Connect Work Tools guarantees that the product shall be free from defects in materials or workmanship for a period of 12 months of installation date or 18 months from invoice date, whatever comes first.

Before submitting a warranty claim, make sure the attachment qualifies and meets the guidelines for warranty consideration.

Prior to performing a warranty action and submitting Connect Work Tools warranty claim the distributor must obtain pre-approval and a warranty claim number.

Contact the Connect Work Tools Customer Service Department at: 920-238-6657 or Email: [service@connectworktools.com](mailto:service@connectworktools.com)



**CONNECT**<sup>TM</sup>  
**WORK TOOLS**

---

---

**920.238.6657**

*[www.connectworktools.com](http://www.connectworktools.com)*

