

Gas Fired Breakers

Model: CHG10

Parts Manual CHG-Series



Part #CHGE00015

Connect Work Tools - www.connectworktools.com - 920.238.6657

Table of Contents

Contact Information	4
1.0 Equipment Identification	
1.1 Location of Serial Number	5
1.2 Owner's Record of Equipment	5
2.0 Decals	6
3.0 Base Plates	8
4.0 CHG10 Hammer	
4.1 Hammer	10
4.2 Back Head Sub Assembly	11
4.3 Cylinder Sub Assembly	12
4.4 Front Head Sub Assembly	14
4.5 Side Rod Set	15
5.0 CHG10 Housing	16
5.1 Box Housing	16

Contact Information



Connect Work Tools
155 Main Street
Superior, WI 54880

E-mail: info@connectworktools.com
Main Phone: 920-238-6657
Fax: 715-395-3703

Contact your Connect Work Tools Representative or the Connect Work Tools Parts Department for replacement manuals. Inquiries regarding the content of this manual must include the release date shown below.

Information in this manual is subject to change without advance notice.

Table 1.1 About this manual

Document ID No.	CHGE00015
Type	Parts
Release Date	January 2024
Product Name	Gas fired Breakers
Series	CHG
Applicable Models	CHGE
Years of Manufacture	2024 & above

1.0 Equipment Identification

1.1 Location of the Serial Number Decal

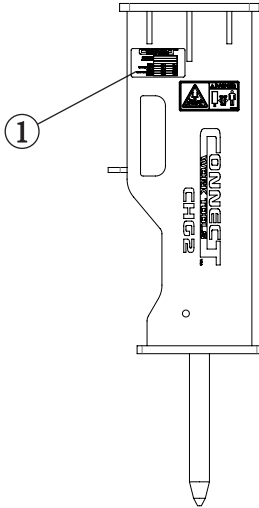

Fig. 1.1 Equipment Identification

The Serial Equipment Identification Decal is affixed to the side of the housing box. It provides the following information:

- Serial Number
- Model
- Part Number
- Weight
- Operating Pressure
- Oil Flow
- Carrier Relief Pressure
- Nitrogen

****Note: Prior to ordering parts, it's important to confirm your model and serial number**

CONNECT™ WORK TOOLS			
Serial Number:			
Model Number:			
Weight:	kg		lb
Operating Pressure:	bar		psi
Oil Flow:	l/min		gpm
Carrier Relief Pressure:	bar		psi
Nitrogen:	bar		psi

1.2 Owner's Record of the Equipment

Record the Model and Serial Number from the Serial Equipment Identification Tag to the space provided below. Indicate the date in which the Connect Work Tools equipment was placed into service.

Model CHG2: CHG2
 Model CHG3: CHG3
 Model CHG6: CHG6
 Model CHG7: CHG7
 Model CHG9: CHG9
 Model CHG10: CHG10
 Model CHG15: CHG15

Serial Number: _____

In Service Date: _____

Your Connect Work Tools representative requires this information to better assist you with questions regarding parts, warranty, operation, maintenance, or repair.

Your equipment must be registered by your local Distributor at the time of sale.

Product Registration Date: _____

2.0 Decals

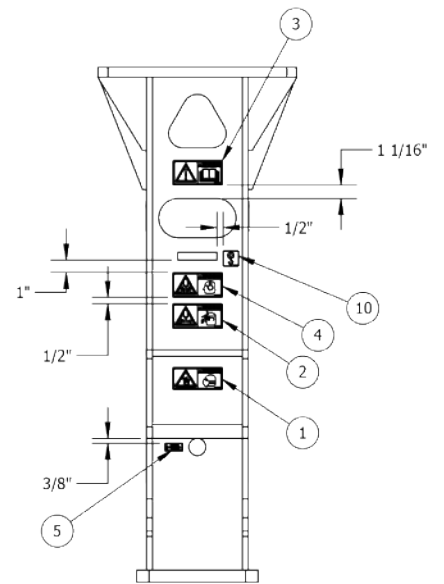
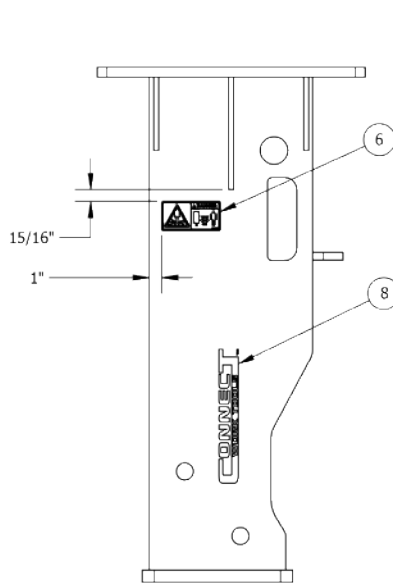
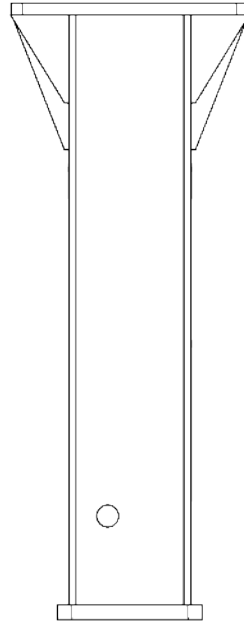
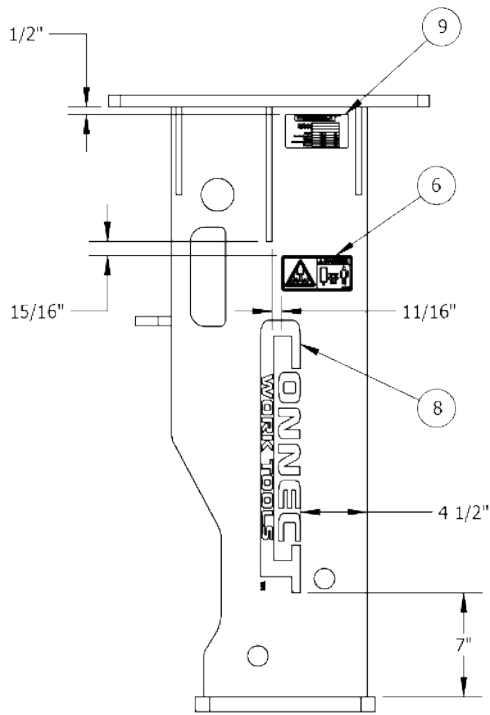

2.0 Decals

All decals pictured are included in decal kits (with exception of No. 10)

2.1 Standard Decals



1. Part Number 16-00076 - Decal Warning Dust



2. Part Number 16-00077 - Decal Warning Flying Objects



3. Part Number 16-00078 - Decal Warning Read Manual



4. Part Number 16-00079 - Decal Warning Noise



5. Part Number 16-00080 - Decal Grease Point



6. Part Number 16-00086 - Decal Warning Safe Distance



7. Part Number CHG00008 - Decal CHG10



8. Part Number CHE00166 - Decal Connect Logo 11" - CHG2/CHG3/CHG6/CHG7
Part Number CHE00109 - Decal Connect Logo 18" - CHG9/CHG10/CHG15



9. Part Number CHE00127 - Decal SN Plate (Not included in Decal Kit)



10. Part Number 16-00082 - Decal Lift Point



11. Part Number CHE00111 - Decal Warning Nitrogen

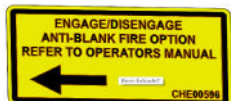

12. Part Number CHE00596 - Decal Warning Anti-Blank Fire

3.0 Base Plates

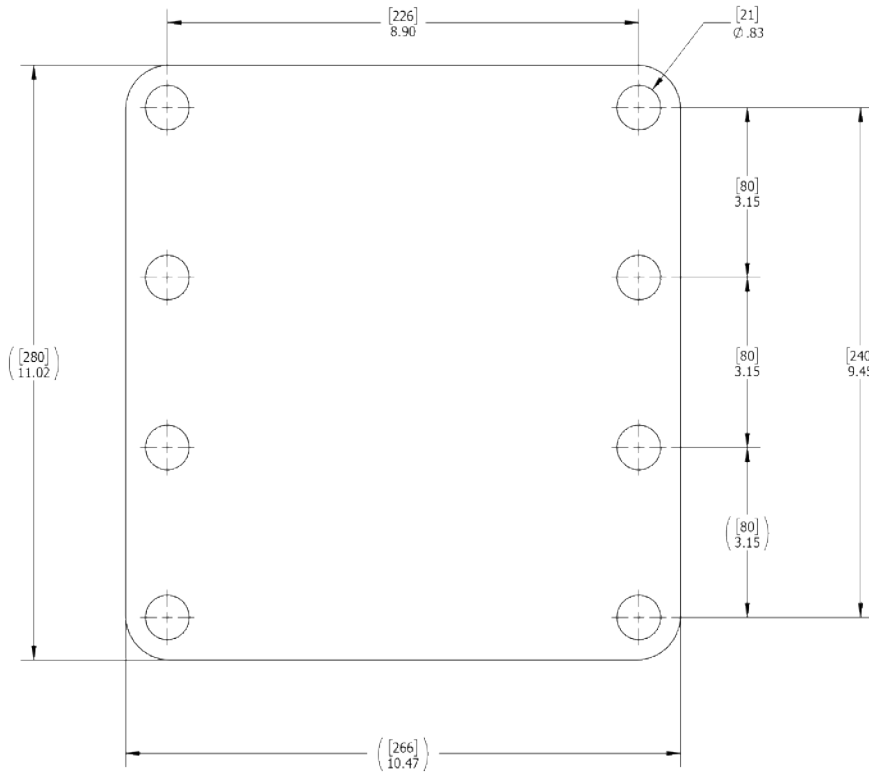

CHGE00101 - CHG2 - BASE PLATE

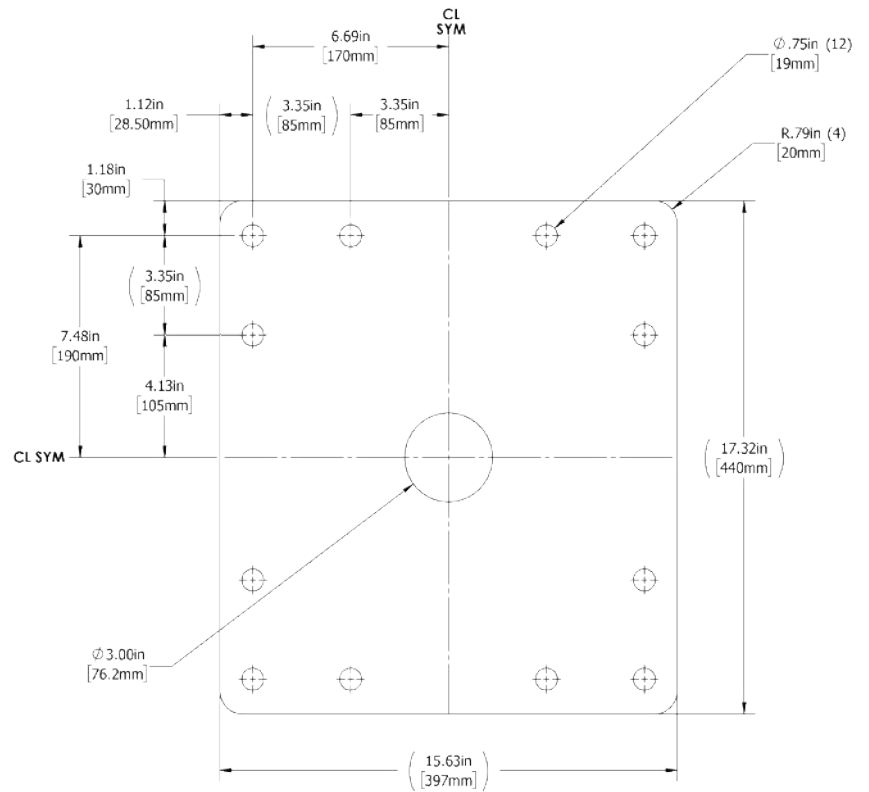

CHE00100 - CHG3/CHG6/CHG7 - BASE PLATE

3.0 Base Plates

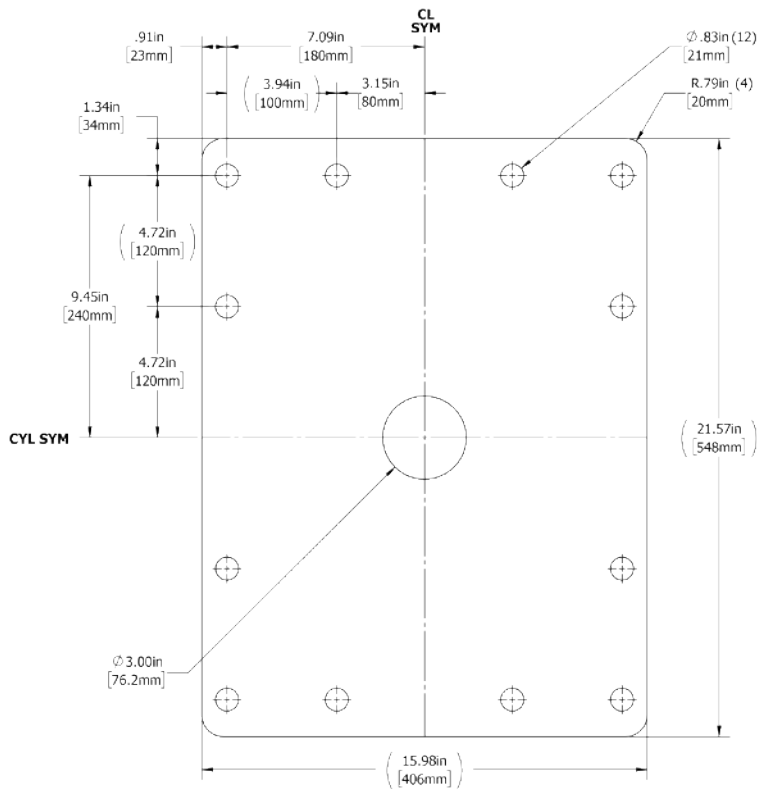

CHE00101 - CHG9/CHG10 - BASE PLATE

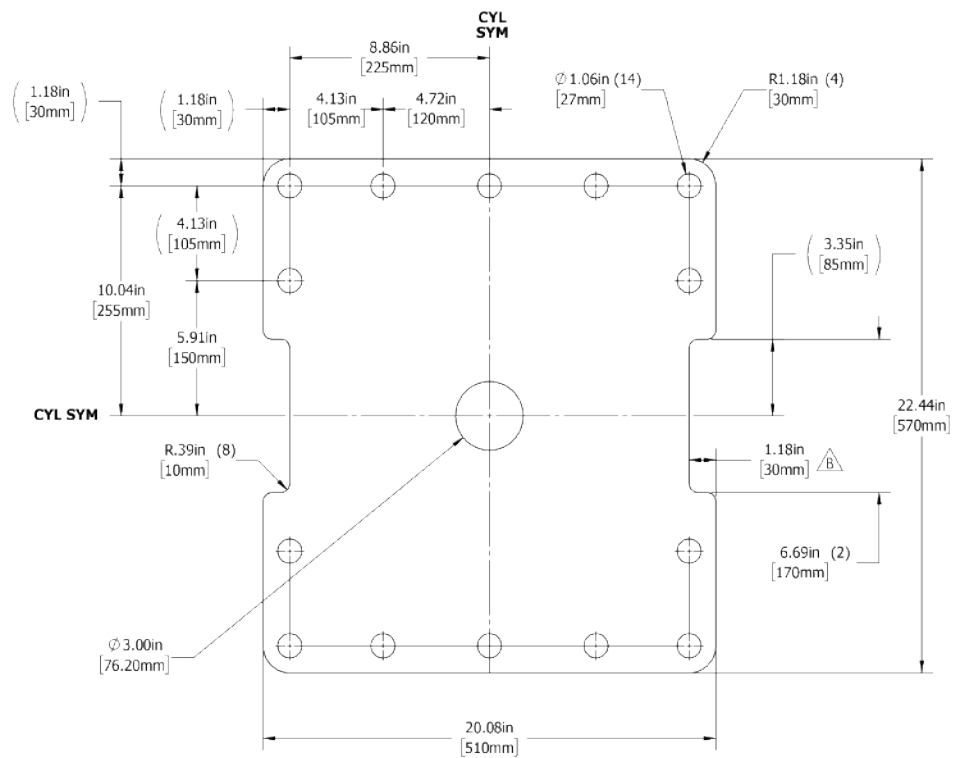

CHE00103 - CHG15 - BASE PLATE

4.0 CHG10 Hammer

4-1. Hammer

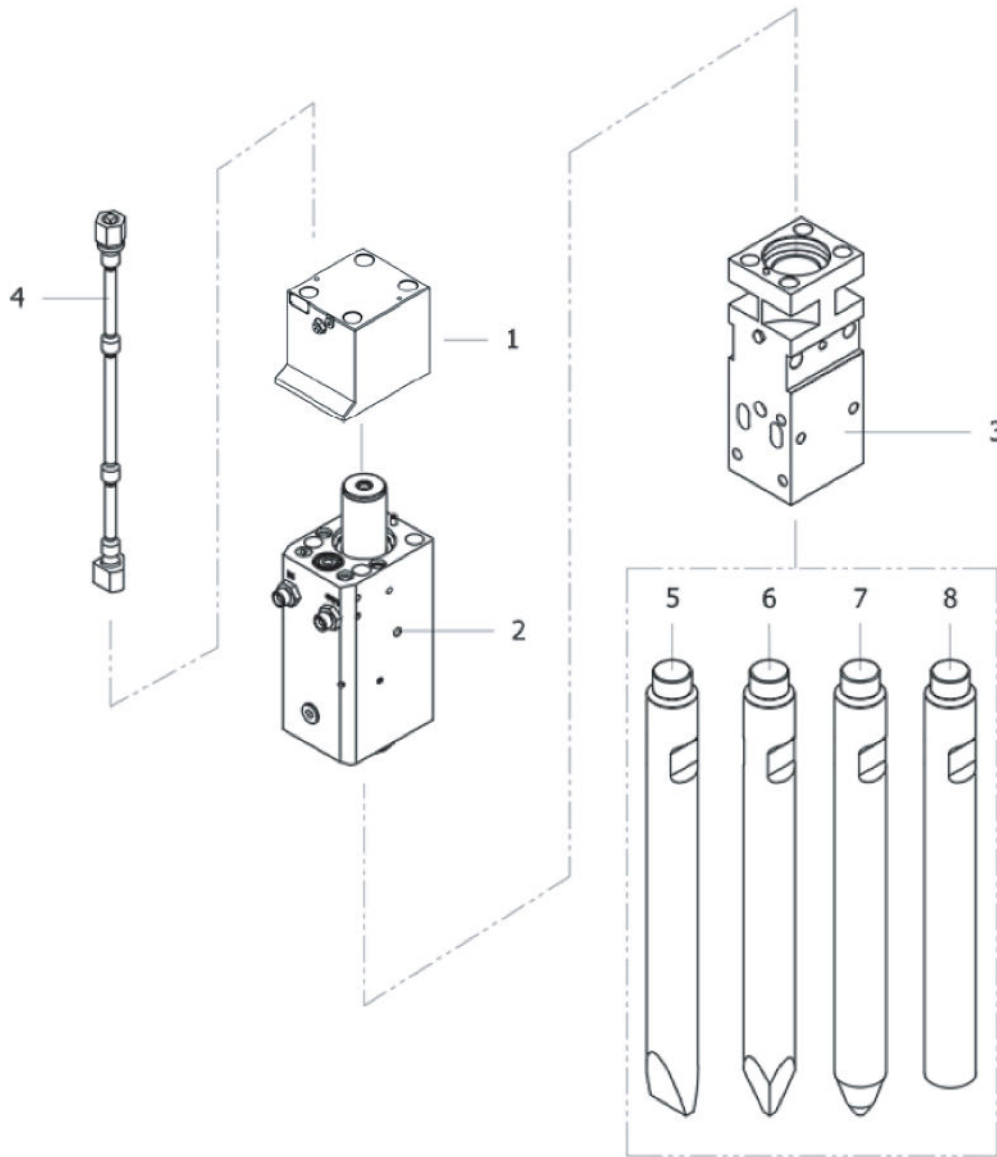

NO.	PART NO.	PART NAME	QTY	REMARKS
	CHG1000000	HAMMER TOTAL ASSEMBLY	1	
1	CHG1001000	BACK HEAD SUB ASSEMBLY	1	
2	CHG1002000	CYLINDER SUB ASSEMBLY	1	
3	CHG1003000	FRONT HEAD SUB ASSEMBLY	1	
4	CHG1004000	SIDE ROD SET	4	
5	CHG1005000	CHG10 CHISEL	1	
6	CHG1006000	CHG10 MOIL	1	
7	CHG1007000	CHG10 CONE	1	
8	CHG1008000	CHG10 BLUNT	1	

4.0 CHG10 Hammer

4-2. Back Head Sub Assembly

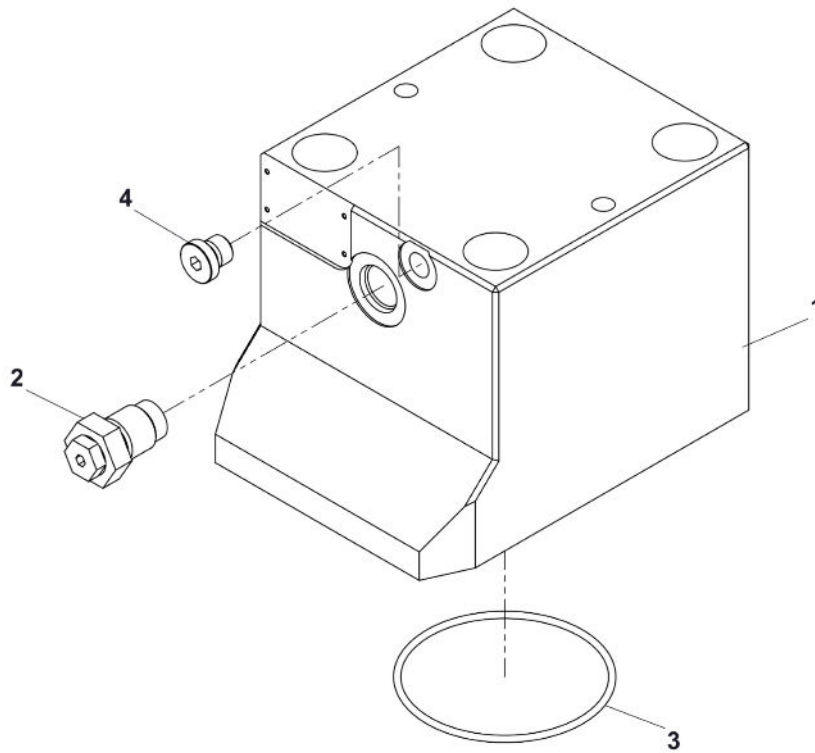

NO.	PART NO.	PART NAME	QTY	REMARKS
	CHG1001000	BACK HEAD SUB ASSEMBLY	1	
1	CHG1001001	CHG10 BACK HEAD	1	
2	CHG0201003	GAS CHARGING VALVE ASSEMBLY	1	
3	CHG1001003	O-RING	1	PART OF SEAL KIT
4	CHG0721004	PLUG	1	

4.0 CHG10 Hammer

4-3. Cylinder Sub Assembly

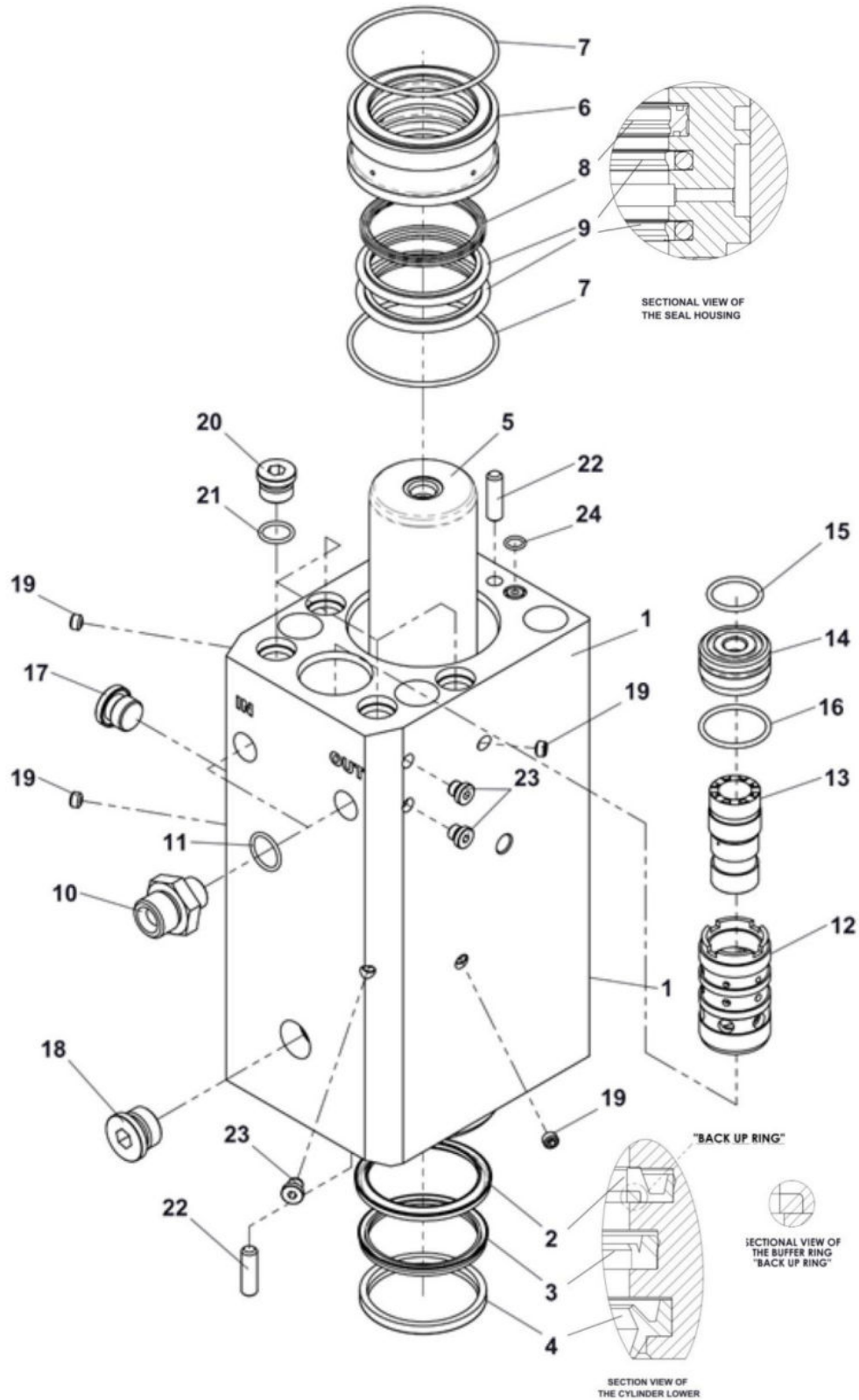

4.0 CHG10 Hammer

NO.	PART NO.	PART NAME	QTY	REMARKS
	CHG1002000	CYLINDER SUB ASSEMBLY	1	
1	CHG1002001	CHG10 CYLINDER	1	
2	CHG1002002	BUFFER RING	1	PART OF SEAL KIT
3	CHG1002003	U-PACKING	1	PART OF SEAL KIT
4	CHG1002004	WIPER	1	PART OF SEAL KIT
5	CHG1002005	PISTON	1	
6	CHG1002006	SEAL HOUSING	1	
7	CHG1002007	O-RING	2	PART OF SEAL KIT
8	CHG1002008	GAS SEAL	1	PART OF SEAL KIT
9	CHG1002009	STEP SEAL	2	PART OF SEAL KIT
10	CHG1002025	ADAPTER	2	PF 3/4" - OPTION
11	CHG0922014	O-RING	2	OPTION
12	CHG1002012	OPER. VALVE GUIDE	1	
13	CHG1002013	OPER. VALVE SPOOL	1	
14	CHG1002014	OPER. VALVE COVER	1	
15	CHG0922014	O-RING	1	PART OF SEAL KIT
16	CHG1002016	O-RING	1	PART OF SEAL KIT
17	CHG0722016	SOCKET PLUG	1	
18	CHG0602014	SOCKET PLUG	1	
19	CHG0722017	SET SCREW	4	
20	CHG0722018	SOCKET PLUG	3	
21	CHG0722019	O-RING	3	PART OF SEAL KIT
22	CHG0203007	GUIDE PIN	2	
23	CHG0602013	SOCKET PLUG	3	
24	CHG0722023	O-RING	1	PART OF SEAL KIT

4.0 CHG10 Hammer

4-4. Front Head Sub Assembly

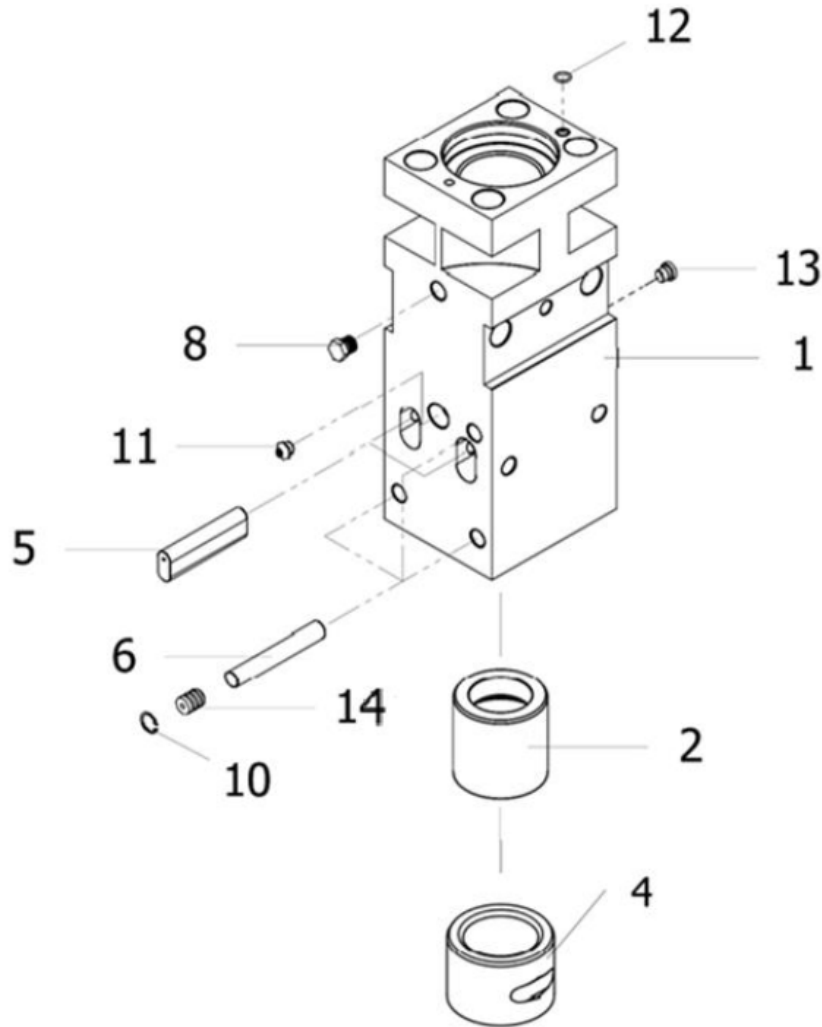

NO.	PART NO.	PART NAME	QTY	REMARKS
	CHG1003000	FRONT HEAD SUB ASSEMBLY	1	
1	CHG1003001	FRONT HEAD	1	
2	CHG1003002	UPPER BUSHING	1	
4	CHG1003004	TOOL BUSHING	1	
5	CHG1003014	CHG10 TOOL PIN	2	
6	CHG1003006	BUSHING PIN (LOWER)	3	
8	CHG0722016	SOCKET PLUG	1	
10	CHG0923010	SNAP RING	3	
11	CHG0203004	GREASE NIPPLE	1	
12	CHG0302008	O-RING	1	
13	CHG0202011	PLUG	1	
14	CHG1003014	RUBBER PLUG	3	

4.0 CHG10 Hammer

4-5. Side Rod Set

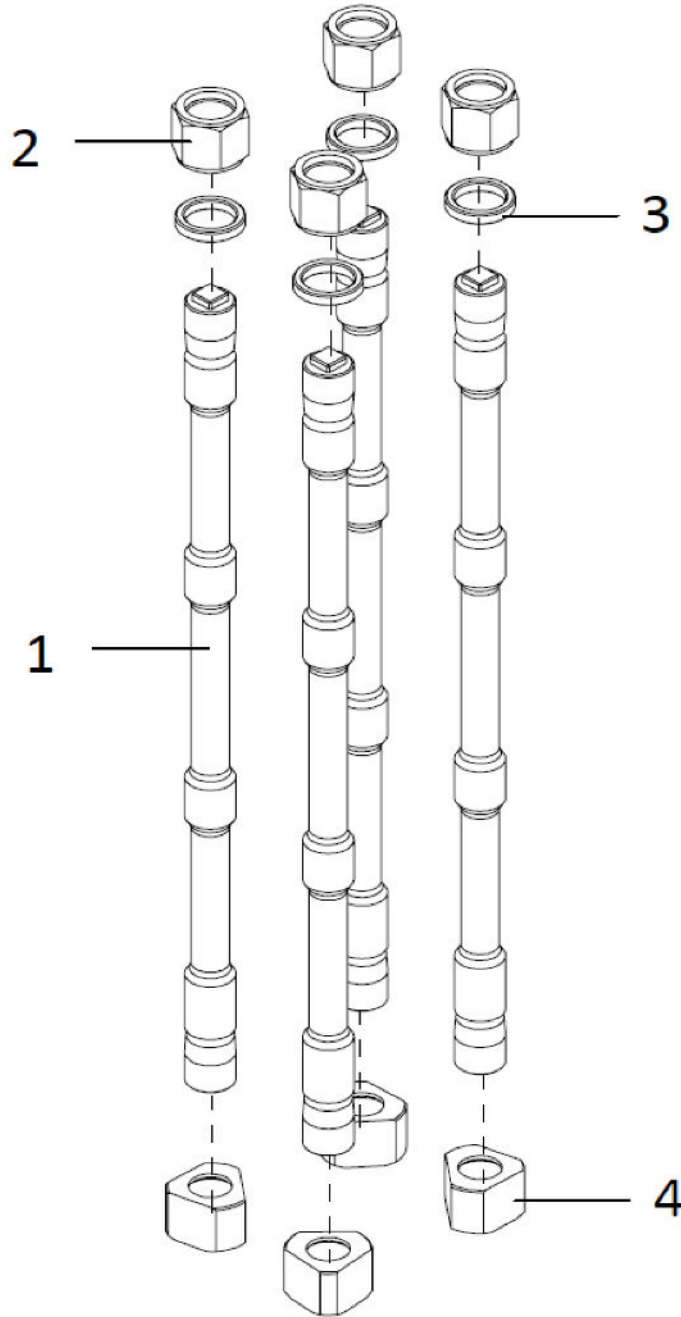

NO.	PART NO.	PART NAME	QTY	REMARKS
	CHG1004000	SIDE ROD SET	4	
1	CHG1004001	CHG10 SIDE ROD	4	
2	CHG1004002	SIDE ROD NUT (UPPER)	4	
3	CHG1004003	SIDE ROD WASHER	4	
4	CHG1004004	SIDE ROD NUT (LOWER)	4	

5.0 CHG10 Housing

5-1. Box Housing

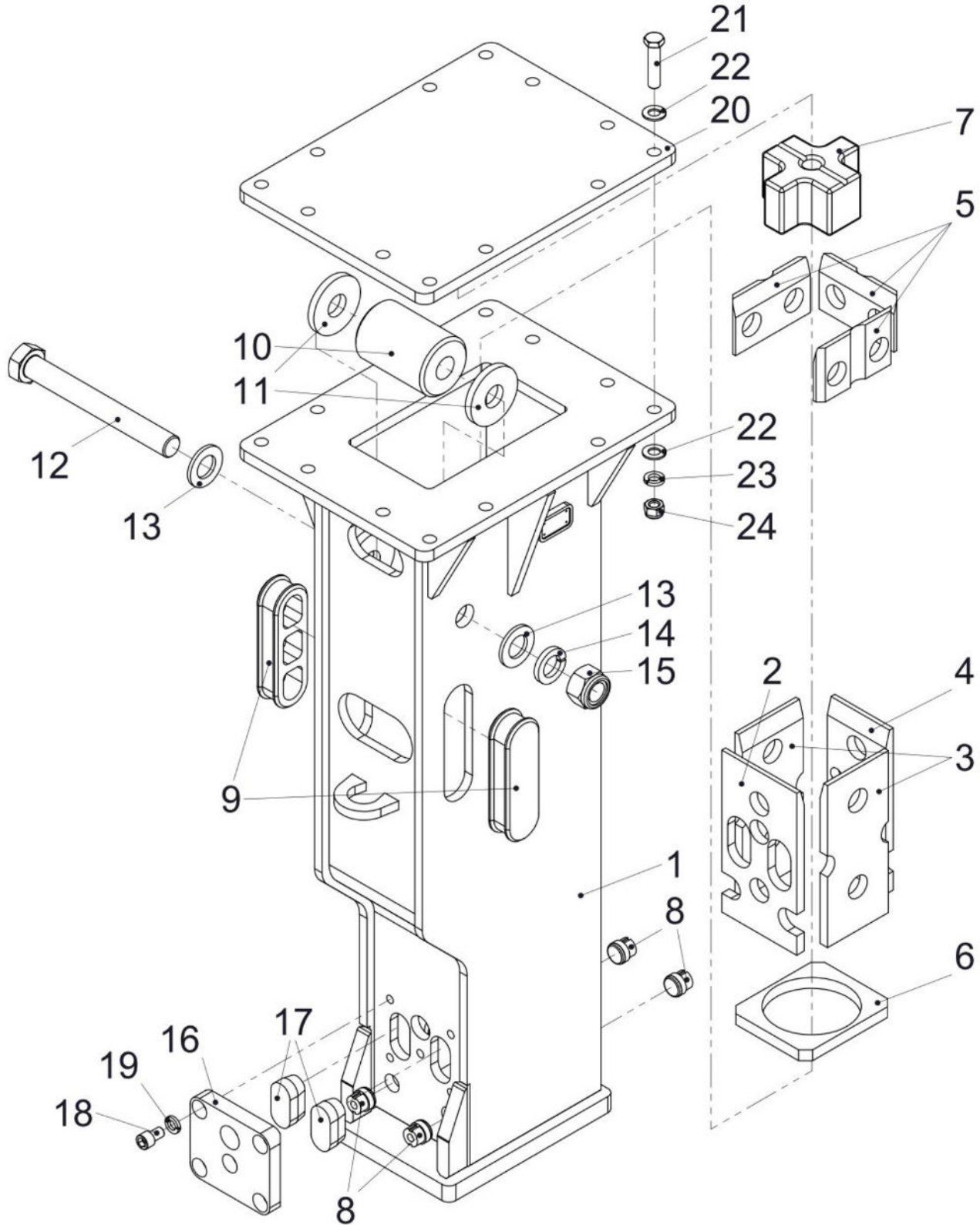

5.0 CHG10 Housing

NO.	PART NO.	PART NAME	QTY	REMARKS
	CHG1055000	HOUSING TOTAL ASSEMBLY	1	
1	CHG1055001	HOUSING WELD ASSEMBLY	1	
2	CHG1053007	WEARING PLATE	1	
3	CHG1053008	WEARING PLATE	2	
4	CHG1053006	WEARING PLATE	1	
5	CHG1053005	WEARING PLATE	3	
6	CHG1053003	BASE BUFFER	1	
7	CHG1053004	TOP BUFFER	1	
8	CHG1053009	RUBBER PLUG	4	
9	CHG1053025	RUBBER PLUG	2	
10	CHG1053011	SIDE BUFFER	1	
11	CHG1053012	WASHER	2	
12	CHG1053015	HEX. BOLT	1	
13	CHG1053016	PLAIN WASHER	2	
14	CHG1053014	SPRING WASHER	1	
15	CHG1053013	NYLON NUT	1	
16	CHG1053021	HOUSING TOOL PIN COVER	1	
17	CHG1053010	TOOL PIN COVER	2	
18	CHG1053023	SOCKET BOLT	5	
19	CHG1053022	SPRING WASHER	5	
20	CHG1055002	TOP COVER PLATE	1	OPTION
21	CHG1053017	HEX. BOLT	12	
22	CHG1053018	PLAIN WASHER	24	
23	CHG1053019	SPRING WASHER	12	
23	CHG1053020	NYLON NUT	12	



CHG Series Gas Fired Hammers Limited Warranty

Connect Work Tools offers this warranty to owners of new Connect Work Tools equipment that, after delivery and placement into service by the first user, the authorized Connect Work Tools Distributor in whose service area the product is operated will repair or replace any part that fails because of defects in material or workmanship. Connect Work Tools warranty covers new or original equipment only. This warranty does not apply to used equipment, that has been in service beyond the new product warranty period.

STANDARD RATE SCHEDULE

The following rate schedule is in effect and will be applied when evaluating and processing all related requests.

Warranty Coverage:

CHG2 - CHG3 - CHG6 - CHG7 - CHG9 - CHG10 - CHG15

Months	Parts	Labor
0-12	No Change	No Change

Connect Work Tools guarantees that the product shall be free from defects in materials or workmanship for a period of 12 months of installation date or 18 months from invoice date, whatever comes first.

Before submitting a warranty claim, make sure the attachment qualifies and meets the guidelines for warranty consideration.

Prior to performing a warranty action and submitting Connect Work Tools warranty claim the distributor must obtain pre-approval and a warranty claim number.

Contact the Connect Work Tools Customer Service Department at: 920-238-6657 or Email: service@connectworktools.com

CONNECTTM
WORK TOOLS

920.238.6657

www.connectworktools.com

