



# Gas Fired Breakers

## Models

CHG3

CHG6

CHG7

CHG9

CHG10

CHG15

# Operator's Manual CHG-Series

Safety, Operation & Maintenance

Part #CHGE00001



Connect Work Tools - [www.connectworktools.com](http://www.connectworktools.com) - 920.238.6657



## Contact Information



**Connect Work Tools**  
**155 Main Street**  
**Superior, WI 54880**

**E-mail: [info@connectworktools.com](mailto:info@connectworktools.com)**  
**Main Phone: 920-238-6657**  
**Fax: 715-395-3703**

Contact your Connect Work Tools Representative or the Connect Work Tools Parts Department for replacement manuals.  
Inquiries regarding the content of this manual must include the release date shown below.

**Information in this manual is subject to change without advance notice.**

**Table 1.1 About this manual**

Document ID No.	CHGE00001
Type	Safety, Operation and Maintenance
Release Date	August 2023
Product Name	Gas Powered Impact Breaker
Series	CHGE
Applicable Models	CHGE3/CHGE6/CHGE7/CHGE9/ CHGE10/CHGE15
Years of Manufacture	2023 & above

# Safety Information

## Safety Statements and Hazard Alerts

Within this manual, you will find important safety information. The information will include specific information related to the Connect Work Tools attachment as well as the carrier. It is imperative that operators, maintenance personnel, or individuals loading or transporting the equipment read and understand the safety contents of this manual, as well as all safety decals and labels. Safety decals and labels must be kept legible and intact on the attachment. Replace damaged, missing or unlegible safety labels or decals.

## Purpose of Safety Messages

The reason safety messages and information has been included in this manual is most importantly to protect you and those individuals in the work area. Additionally, it is provided to eliminate damage to surroundings, attachments and the carrier due to incorrect operation and use or lack of maintenance of the equipment.

## Key Points before operating equipment

1. Know your surroundings, survey the area prior to operation.
2. Know where the potential hazards are within the work area and notify personnel of those hazards.

Safety messages provide the following information:

1. **Alert** personnel to potential hazards
2. **Identify** the nature of the hazard
3. **Describe** the severity of the hazard, if encountered
4. **Instruct** how to avoid the hazard

**ATTENTION, BECOME ALERT, YOUR SAFETY IS INVOLVED.**

## Signal Words

Safety symbols and signal words, as shown below, are used to emphasize all operator, maintenance and repair actions which, if not strictly followed, could result in a life-threatening situation, bodily injury or damage to equipment.



*This is the safety alert symbol. It is used to alert you to potential personal injury hazards. Obey all safety messages that follow this symbol to avoid possible injury or death.*



*This safety alert and signal word indicates an imminently hazardous situation which, if not avoided, will result in death or serious injury.*



*This safety alert and signal word indicates a potentially hazardous situation which, if not avoided, could result in death or serious injury.*



*This safety alert and signal word indicates a potentially hazardous situation which, if not avoided, may result in minor or moderate injury.*



*This signal word indicates a potentially hazardous situation which, if not avoided, may result in property damage or damage to the equipment.*



*This signal word indicates a situation which, if not avoided, may result in damage to the equipment.*

Fig. S1 Safety Signal Words

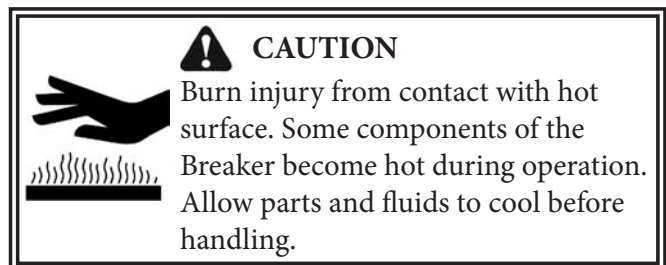

Fig. S2 Safety Message

## Signal Words Used for Non-Hazard Messages

This manual contains other message types that use the signal words IMPORTANT and NOTE. These are information messages that provide instructions and are not considered hazardous to workers.

**IMPORTANT** - Identify instructions that if not followed, may damage the equipment or diminish the service life of components.

**NOTE** - Highlight suggestions, which will enhance installation, reliability, or operation.







# Safety Information

## Safety, Information and Identification Labels







Information labels affixed to the Connect Work Tools equipment include safety warnings, identification and instructions important to operation and service. Refer to Figure "L-15" for their location on the equipment.

Keep all safety & identification labels clean. Words and illustrations must be legible.

Before operating this equipment, replace damaged or missing labels. For replacement, refer to the appropriate Parts Manual for identification.

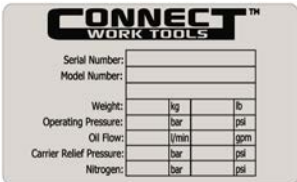
Fig.	Label	Description
Fig. L-1		<b>DUST MASK REQUIRED</b> - Decal alerts personnel of a possible breathing hazard. Individuals will be required to wear the proper breathing PPE in this environment.
Fig. L-2		<b>FLYING OBJECTS</b> - Decal alerts of the risk of injury from impact by rock fragments. Protective guards must be placed between the breaker and operator to shield against material fragments becoming projectiles. It directs personnel to the safety instructions in the Operator's Manual. <b>NOTE: Place the smaller size decal in a conspicuous location inside the operator's cab.</b>
Fig. L-3		<b>READ INSTRUCTIONS</b> - Decal directs personnel to the manual for further information/instructions.
Fig. L-4		<b>HEARING PROTECTION REQUIRED</b> - Decal alerts personnel of loud, harmful noises. Individuals will be required to wear the proper hearing PPE in this environment.
Fig. L-5		<b>GREASE POINT DECAL</b> - Directs personnel where to grease the equipment.
Fig. L-6		<b>STAY CLEAR</b> - Decal alerts personnel and by-standers to maintain a safe distance from the Breaker while in operation.

# Safety Information

Fig.	Label	Description
Fig. L-7		<b>MODEL</b> - Decal identifies the specific model.
Fig.L-8		<b>CONNECT WORK TOOLS LOGO</b> - This decal is the Connect Work Tools identifier and is a registered trademark of Connect Work Tools.
Fig. L-9		<b>SERIAL PLATE</b> - Contains identifying information about the equipment, including: Manufacturer's name, serial number, model number, part number, product weight, operating pressure, oil flow, carrier relief pressure, and nitrogen pressure.
Fig L-10		<b>LIFT POINT</b> - Decal identifies approved lift points.
Fig L-11		<b>PRESSURIZED NITROGEN ACCUMULATOR</b> - Decal warns of pressurized gas and directs personnel to the Repair Manual for service instructions.
Fig L-12		<b>ANTI-BLANK FIRE</b> - Decal identifies Anti-Blank Fire location and access.

# Safety Information

## CHG2 Decal Placement

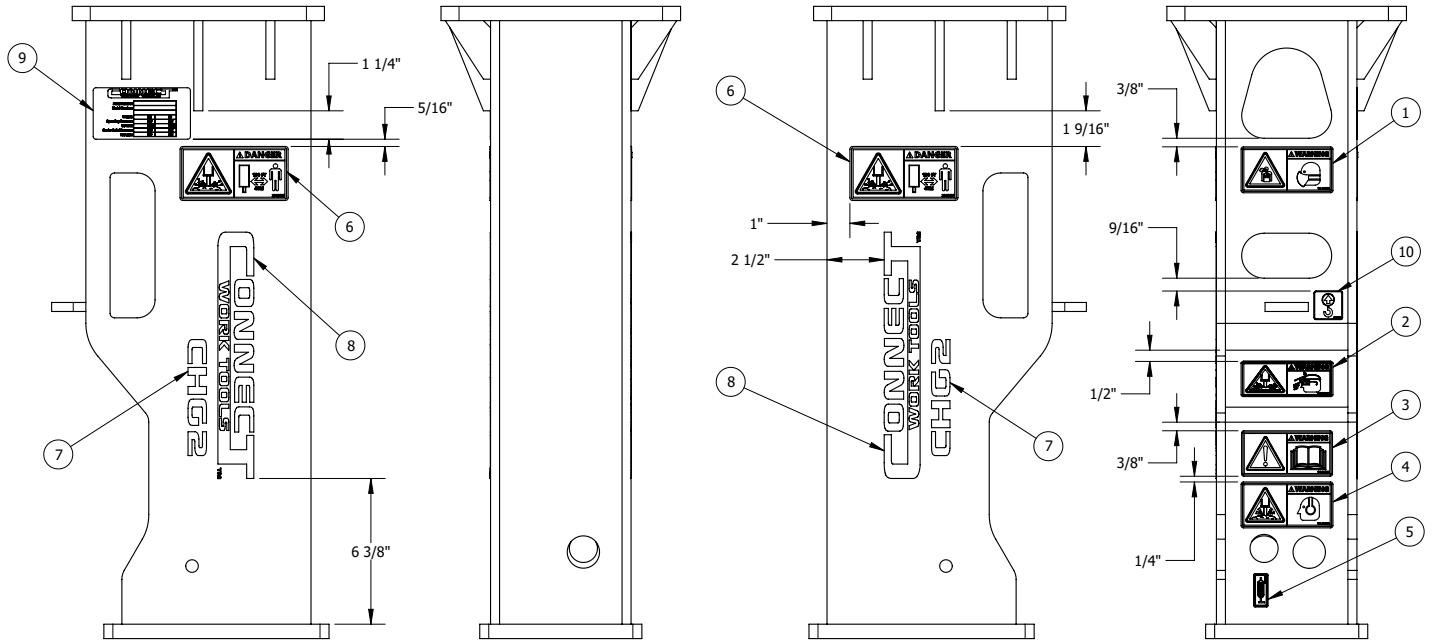

Fig. L13. CHG2 Decal Placement

## CHG3 Decal Placement

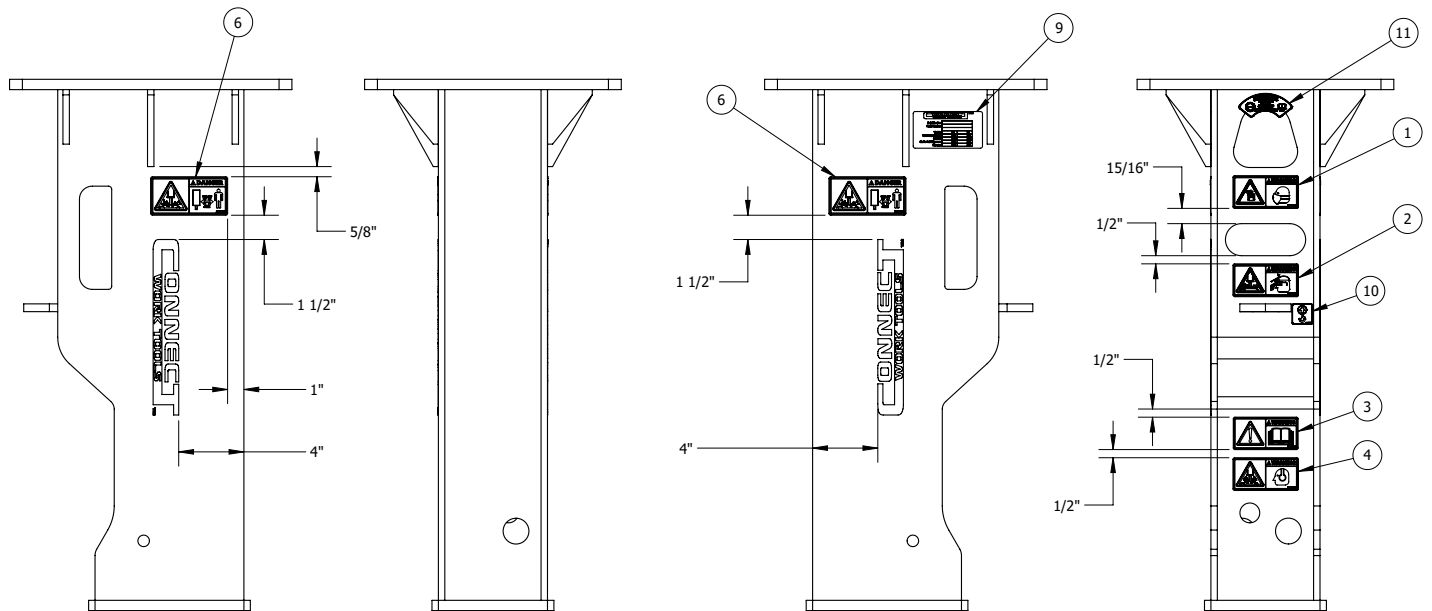

Fig. L14. CHG3 Decal Placement

# Safety Information

## CHG6 Decal Placement

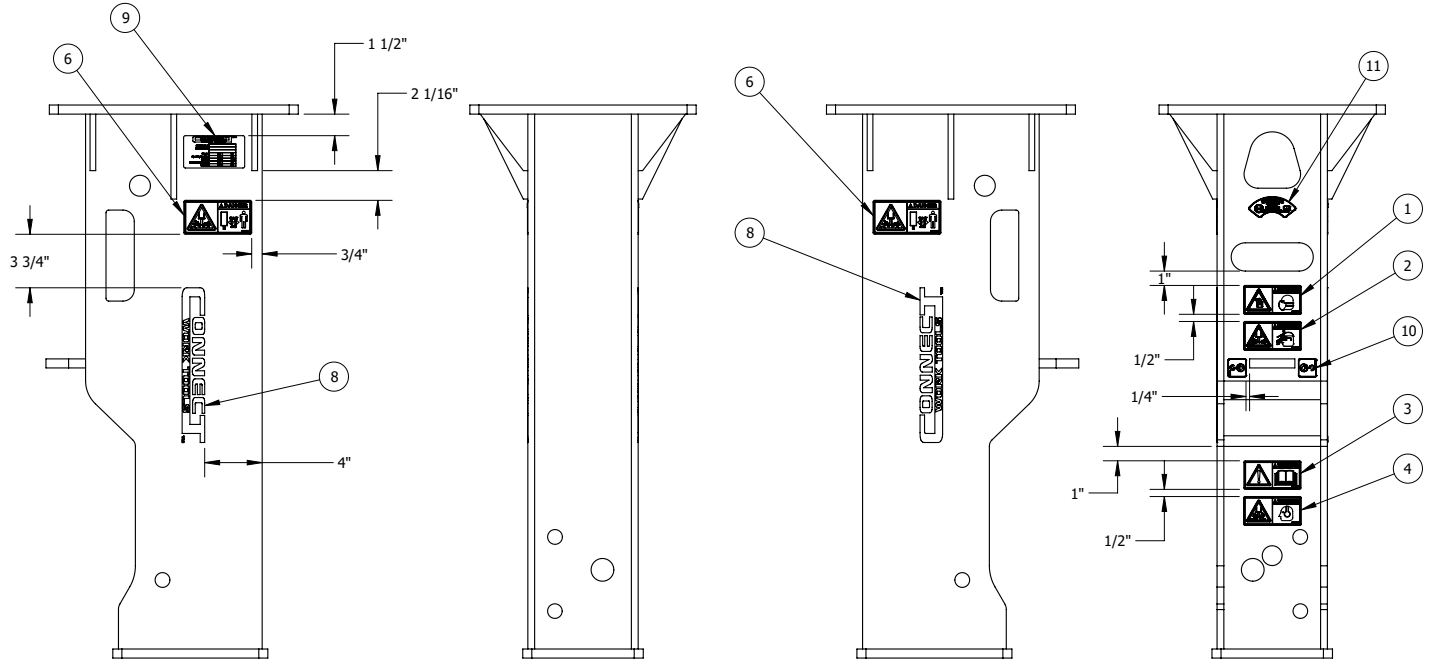

Fig. L15. CHG6 Decal Placement

## CHG7 Decal Placement

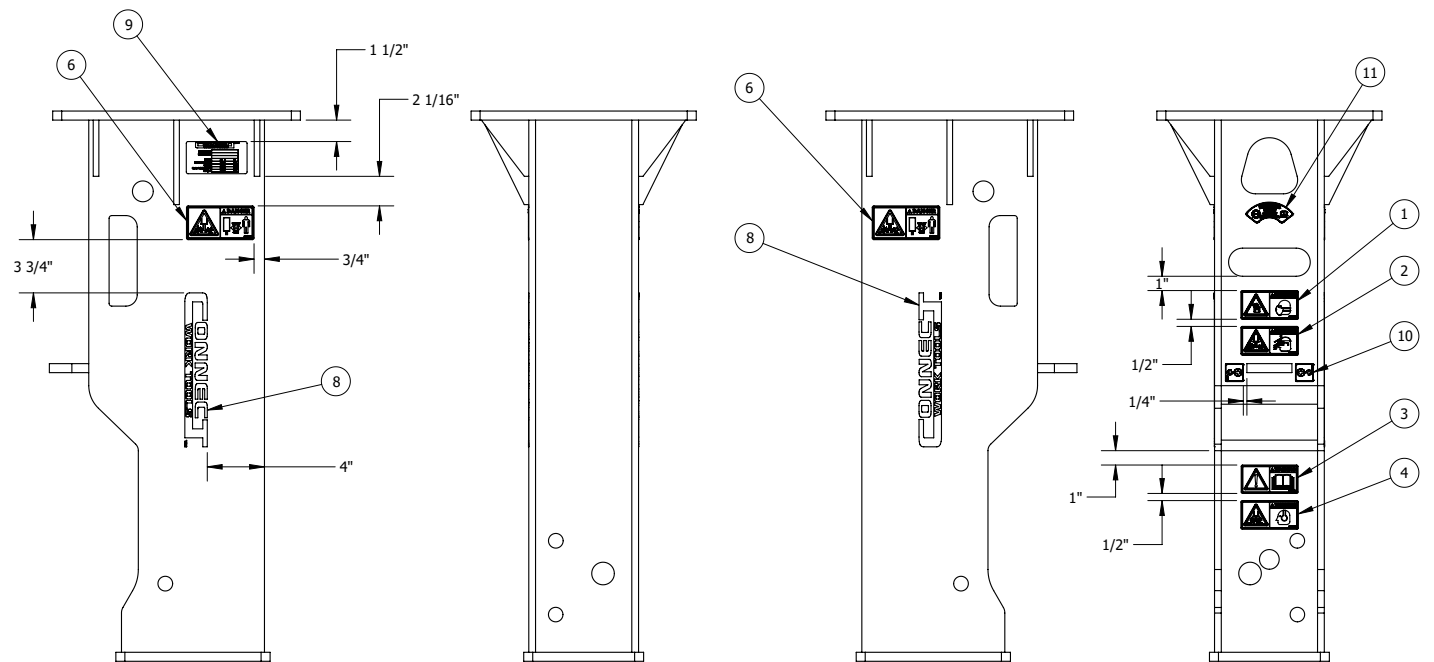

Fig. L16. CHG7 Decal Placement



# Safety Information

## CHG10 Decal Placement

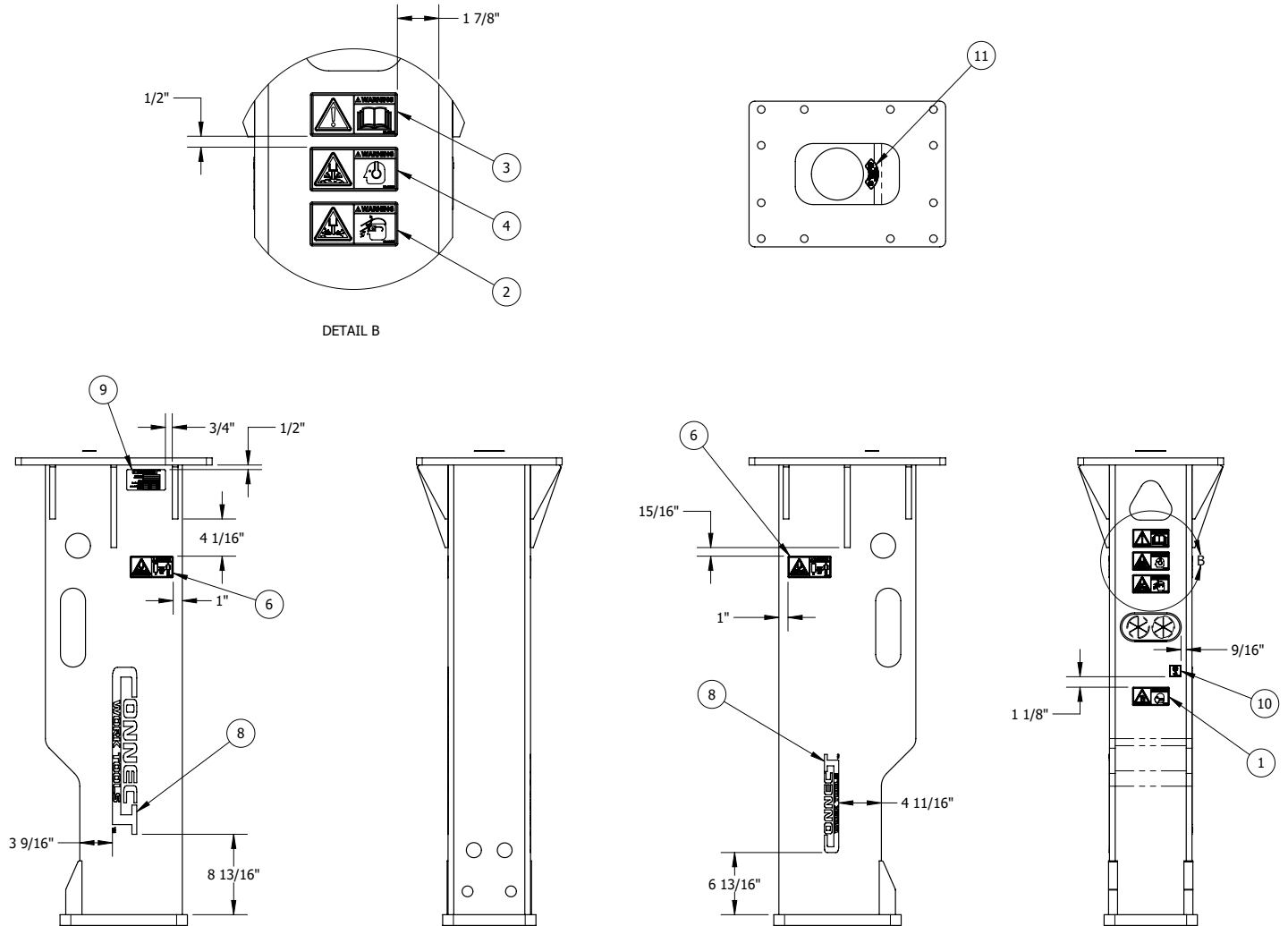

Fig. L16. CHG10 Decal Placement

# Safety Information

## CHG9 Decal Placement

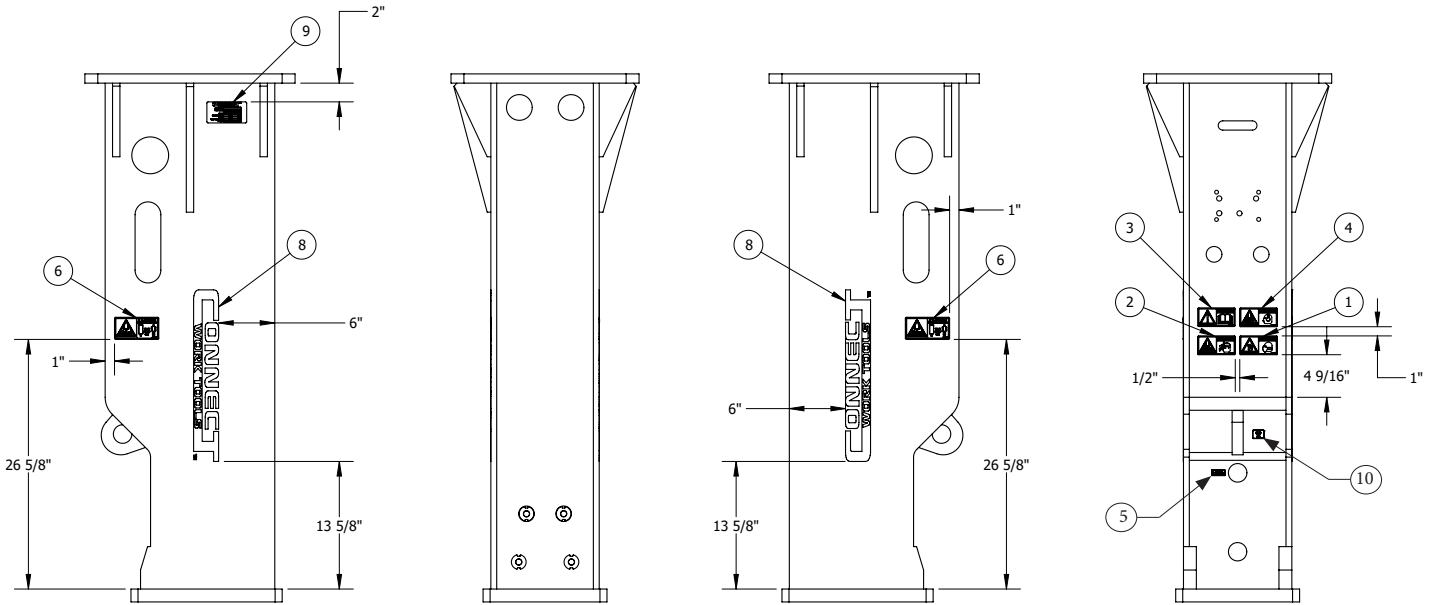

Fig. L16. CHG9 Decal Placement

## CHG15 Decal Placement

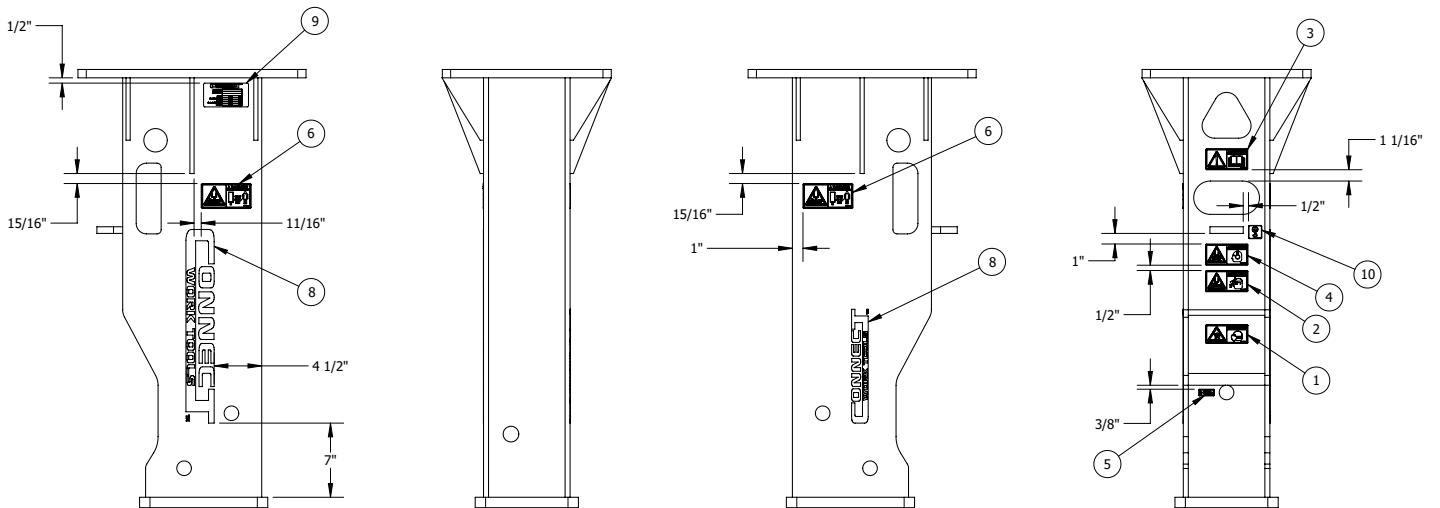

Fig. L16. CHG15 Decal Placement

# Safety Information

## Meaning of Pictograms

Pictograms are used to rapidly communicate information. For the purposes of this manual and labels affixed to the Connect Work Tools equipment, pictograms are defined as follows:



- Read the Manual
- Refer to the manual for further details
- Procedures are explained in the manual



Read the Service Manual for Additional Information



- Crush Point



- Pinch Point



Moving part (in direction indicated by arrow)



- Falling object
- Unsupported loads

### Personal Protection Equipment



- Hearing Protection



- Safety Eyewear



- Gloves



- Safety Shoes
- Falling Part

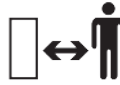

Personnel maintain a safe distance from breaker



Fragments/debris becoming airborne projectiles

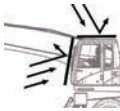

Protective guards required on cab when operating this work tool



Leaking fluid under pressure



Hot Surfaces



Gas/Oil under pressure



Shut off carrier & remove key before servicing



Identifies lift point



Any figure displaying an X-out or a circle with a diagonal slash is a prohibited action



Prohibited actions must be avoided to prevent injury and/or equipment damage



The check mark is used to indicate correct actions or approved methods that are recommended

Fig. S3 Meaning of Pictograms

## Safety Information

### Attention Read the Manual



Improper installation, operation or maintenance of the Connect Work Tools Equipment could result in serious injury or death. Only qualified operators may operate the Connect Work Tools equipment. Personnel responsible for the maintenance of the Connect Work Tools equipment or its systems, including inspection, installation or adjustments must also be qualified. Operators and personnel responsible for the maintenance of this equipment should read this manual. Other manuals, such as those published by the machinery used in support of the Connect Work Tools equipment, should also be read.

### General Construction Safety

Always follow procedures that promote safe conditions for workers and bystanders. The standard safety precautions expected and required of those working in construction shall include, but not limited to:

- Locating existing underground service and utility lines
- Establishing pedestrian barriers
- Using personal protection equipment appropriate to working conditions, etc.

### Owner's Responsibilities

Ensure that only qualified personnel operate and service the Connect Work Tools equipment.

Ensure personal protection equipment is available to personnel and enforce the use of PPE.

Ensure that carriers are in safe, working order and all guards and safety equipment is installed and in operating condition.

Ensure safety-related materials such as instructions and including this manual are kept in a convenient location so that they are easily accessible to operators and maintenance personnel.

### Personal Protective Equipment (PPE)



Personnel operating or nearby the equipment and exposed to the hazard of falling, flying and splashing objects, or exposed to harmful dusts, fumes, mists, vapors, or gases shall use the particular personal protective equipment (PPE) necessary to protect them from the hazard. Such PPE may include safety eyewear, face shield, hearing protection, safety footwear, gloves and dust mask. Supervisors shall review proper PPE selection and ensure PPE is made available to personnel. Personnel are responsible for wearing PPE as directed by the supervisor.

### Protective Equipment - Guarding



Construction equipment designed with guards shall have guards in place when equipment is in use. Guards are fitted to the equipment to protect against unsafe situations that could not be eliminated through design measures. Where it was not possible to prevent an unsafe situation by means of a guard, safety messages appear on the equipment, warning personnel of a hazardous condition.

Guards shall not be removed unless for the purpose of inspection and service of components. All guards must be reinstalled after service or adjustments are completed. Do not operate the Connect Work Tools attachments without guards.

Additional guarding, not included with the Connect Work Tools equipment, is necessary at the operator's station to protect the operator and other nearby personnel against flying debris from material being cut or demolished. Do not handle, demolish or cut material overhead without proper guards installed.

To prevent accidental start up, the control switch shall be located in a protected area that is guarded and makes it difficult to accidentally operate the equipment.

## Safety Information

### Unapproved Modifications



In order to provide and maintain efficient production and reliable service, while ensuring operator safety, the Connect Work Tools equipment may not be modified or used for any other purpose other than, for which it was intended. Use of the Connect Work Tools equipment, other than those specified in this manual, may place personnel at risk of injury and/or may subject the equipment to damage. The Connect Work Tools equipment shall not be modified or used in unapproved applications unless written consent is received from the Connect Work Tools Engineering Department.

# Table of Contents



## Section

<b>Safety Information</b>	ii
<b>Table of Contents</b> .....	xii
<b>General Information</b>	
Introduction .....	1
Safety Precautions .....	1
<b>Technical Specification</b>	
General Specifications .....	2
External Dimensions .....	3
Bolt Pattern - CHG2 .....	4
Bolt Pattern - CHG3, CHG6, CHG7 .....	5
Bolt Pattern - CHG9, CHG10 .....	6
Bolt Pattern - CHG15 .....	7
Tightening Torque Specifications .....	8
<b>Operation</b>	
Guide to Tool Choice .....	9
Preparing for Installation .....	10
Pipe Flushing .....	10
Installation to Excavator .....	10
Removal from Carrier .....	11
Adjustment of BPM and Power .....	11
Adjustment of Auto Shut-off (CHGE15) .....	12
<b>Maintenance</b>	
Product Serial Number .....	13
Periodic Maintenance .....	13
Nitrogen Gas Charging of Back Head .....	14
Lubrication .....	15
Prohibited Operation .....	16
Inspection of Wear condition .....	17
<b>Important Storage Procedures</b>	
Short-Term Storage (up to one month) .....	18
Long-Term Storage (more than one month) .....	18
Correct Greasing .....	18
Breaker Inspection Form .....	19
<b>Accessory Tools</b>	
Accessory Tools .....	20
<b>Troubleshooting Guide</b>	
Hammer does not start .....	21
Low Impact Force .....	21
Slow operation .....	21
Impact rate too high and Impact force too low .....	21
Irregular blow after normal operation .....	21
<b>Dismantling Hammer</b> .....	22
Removing the Tool - CHG2 - 7 .....	22
Removing the Tool - CHG9 .....	23
Removing the Tool - CHG10 and CHG15 .....	24
Disassemble the Hammer Powercell .....	25

# List of Figures



## Figure

Fig. S.1 Safety Signal Words . . . . .	ii
Fig. S. 2 Safety Message . . . . .	ii
Fig. L1-L6 Decal Placement . . . . .	iii
Fig. L7-L12 Decal Placement . . . . .	iv
Fig. L13 CHG2 & CHG3 Decal Layout . . . . .	v
Fig. L14 CHG6 & CHG7 Decal Layout . . . . .	vi
Fig. L15 CHG10 Decal Layout . . . . .	vii
Fig. L16 CHG9 & CHG15 Decal Layout . . . . .	viii
Fig. S.3 Meaning of Pictograms . . . . .	ix
Fig. Sp.1 Box Housing Dimensions . . . . .	3
Fig. Sp.2 Bolt Pattern - CHG2 . . . . .	4
Fig. Sp.3 Bolt Pattern - CHG3, CHG6, CHG7 . . . . .	5
Fig. Sp.4 Bolt Pattern - CHG9 & CHG10 . . . . .	6
Fig. Sp.5 Bolt Pattern - CHG15 . . . . .	7
Fig. Sp 6 Torque Specifications . . . . .	8
Fig. O1 Tool Choice . . . . .	9
Fig. O2 Installation of Excavator . . . . .	10
Fig. O3 Installation of Excavator . . . . .	11
Fig. O4 BPM and Power adjustment . . . . .	11
Fig. O5 Auto Shut-off System (CHGE15) adjustment . . . . .	12
Fig. M1 Serial Number location . . . . .	13
Fig. M2 Nitrogen gas changing of Back Head . . . . .	14
Fig. M3 Lubrication . . . . .	15
Fig. D1 CHG2 - CHG7 . . . . .	22
Fig. D2 CHG2 - CHG7 Pin Removal . . . . .	22
Fig. D3 CHG9 . . . . .	23
Fig. D4 CHG9 Pin Removal . . . . .	23
Fig. D5 CHG10 & CHG15 . . . . .	24
Fig. D6 CHG10 & CHG15 Pin Removal . . . . .	24
Fig. D6 Powercell removal (1) . . . . .	25
Fig. D7 Powercell removal (2) . . . . .	26
Fig. D8 Powercell removal (3) . . . . .	26
Fig. D9 Powercell removal (4) . . . . .	26
Fig. D10 Powercell removal (5) . . . . .	27
Fig. D11 Powercell removal (6) . . . . .	28
Fig. D12 Powercell removal (7) . . . . .	29

Contact your Connect Work Tools Representative or the Connect Work Tools Parts Department for replacement manuals.  
 Inquiries regarding the content of this manual must include the release date shown below  
 Information in this manual is subject to change without advance notice





## *General Information*

### SAFETY INFORMATION

#### GENERAL INFORMATION

This manual is a guidebook to the Connect Work Tools hydraulic breaker. The manual gives instructions on how to use the hydraulic breaker safely and effectively.

Most accidents are caused by the failure to follow fundamental safety rules for the operation and maintenance of machines. Operators and maintenance personnel should read this manual carefully and fully understand all safety guidelines and warnings before operating the machine.

Operators and maintenance personnel should read periodically and always keep it handy. This manual should be kept in good condition and replaced if damaged. Further, this manual should be kept together with the hydraulic excavator manual.

#### PRECAUTIONS FOR SAFETY

Operators should not operate the machine if not in good health condition due to tiredness, lack of sleep and medication.

Operator should wear safety hat and safety shoes. If necessary, operator should wear safety goggles, mask, and ear protection.

Breaker should be installed to the correct specification excavators. If the breaker is too heavy for the excavator, it could be overturned during operation.

In case of using quick coupler, operator should check the specification of total working weight including the weight of quick coupler. Operator should check the coupling status between coupler and breaker.

Operator should secure a clear view enough to operate machine when it is hard to work due to fog, rain or snow.

Operators should always be careful for the flying or fallen from unexpected direction.

Do not operate the breaker without top & front guard shields or FOPS (Falling Objects Protection Structure) between the breaker and the operator.

# Specification

## TECHNICAL SPECIFICATIONS

### GENERAL SPECIFICATIONS

DESCRIPTION	UNITS	CHG2	CHG3	CHG6	CHG7	CHG9	CHG10	CHG15
		BOX	BOX	BOX	BOX	BOX	BOX	BOX
WORKING WEIGHT	Pounds (Kilograms)	326 (148)	415 (188)	657 (298)	747 (339)	908 (412)	1248 (566)	2161 (80)
IMPACT RATE	bpm	700 - 1500	450 - 1150	632 - 1500	600 - 1100	450 - 750	400 - 750	
OPERATING PRESSURE	PSI (bar)	1305 - 1741 (90 - 120)	1305 - 1886 (90 - 130)	1378 - 1886 (95 - 130)	1595 - 2176 (110 - 150)	1378 - 1886 (95 - 130)	1886 - 2176 (130 - 150)	2031 - 2321 (140 - 160)
RELIEF PRESSURE	PSI (bar)	2321 - 2611 (160 - 180)		2901 - 3046 (200 - 210)		2321 - 2611 (160 - 180)		2756 - 2901 (190 - 200)
OIL FLOW	gal/min (l/min)	4-9 (15-35)	7-12 (25-45)	10 - 22 (38 - 83)		11-22 (40-80)	12-23 (45-85)	21-29 (80-110)
BACK PRESSURE	PSI (bar)	145 (10)						
TOOL DIAMETER	Inch (mm)	1.50 (40)	2.17 (55)	2.64 (67)	2.68 (68)	2.95 (75)	3.35 (85)	3.94 (100)
PRESSURE LINE SIZE	Inch (mm)	1/2" (12)		3/4" (19)		1/2" (12)	3/4" (19)	
RETURN LINE SIZE	Inch (mm)	1/2" (12)		3/4" (19)		1/2" (12)	3/4" (19)	
SUITABLE CARRIER WEIGHT	pounds (tons)	2205 - 6614 (1 - 3)	4409 - 9922 (2 - 4.5)	5070 - 13228 (2.3 - 6)	8819 - 13228 (4 - 6)	9921 - 19842 (4.5 - 9)	15432 - 26456 (7 - 12)	24251 - 35274 (11 - 16)
ACCUMULATOR PRESSURE	PSI (bar)	-						
BACK HEAD PRESSURE	PSI (bar)	218 (15)	174 (12)	203 (14)	160 (11)	232 (16)		
OIL TEMPERATURE	°F (°C)	-4°-176° (-20°-80°)						
HYDRAULIC OIL VISCOSITY	cSt	1000 - 15						

# Specification

## EXTERNAL DIMENSIONS

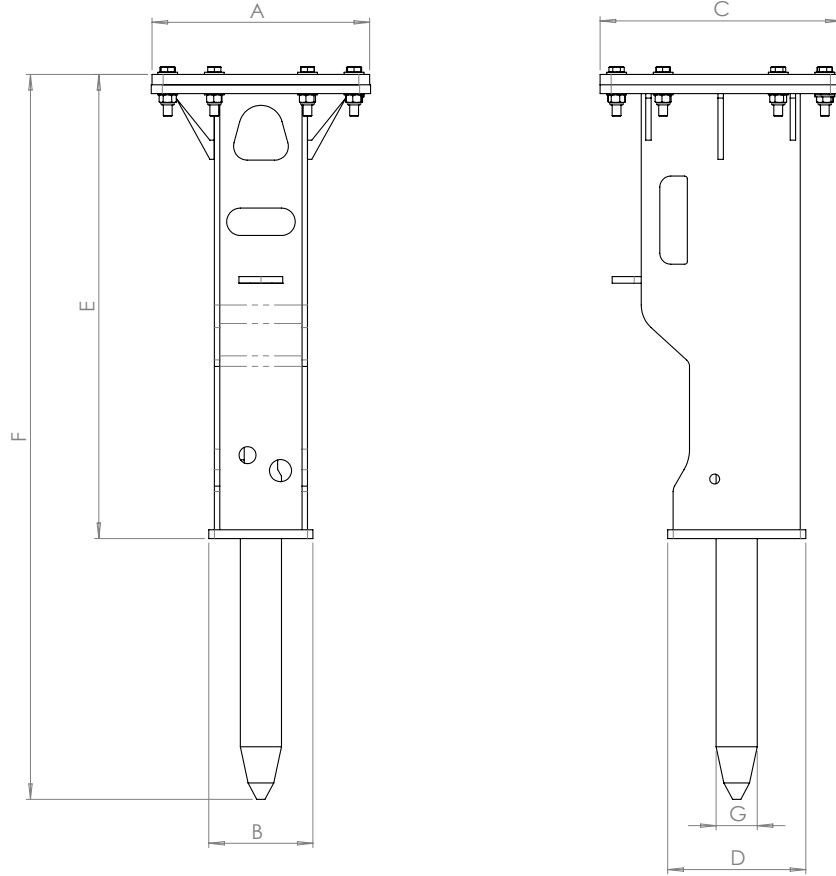

Fig. Sp1. Box Housing Dimensions

DIMENSION	UNITS	CHG2	CHG3	CHG6	CHG7	CHG9	CHG10	CHG15
A	Inch (mm)	10.47 (266)	13.00 (330)	14.65 (372)	14.65 (372)	16.77 (426)	16.77 (426)	19.69 (500)
B	Inch (mm)	7.09 (180)	7.48 (190)	8.39 (213)	8.39 (213)	9.76 (248)	10.24 (260)	13.23 (336)
C	Inch (mm)	11.02 (280)	13.00 (330)	14.17 (360)	14.17 (360)	18.11 (460)	18.11 (460)	23.23 (590)
D	Inch (mm)	7.87 (200)	8.74 (222)	10.89 (274)	9.69 (246)	12.13 (308)	13.96 (355)	16.14 (410)
E	Inch (mm)	28.27 (718)	33.31 (846)	36.26 (921)	39.13 (994)	42.24 (1073)	52.09 (1323)	57.56 (1462)
F	Inch (mm)	40.35 (1025)	46.57 (1183)	50.24 (1276)	54.33 (1380)	59.53 (1512)	73.27 (1861)	75.55 (1919)
G	Inch (mm)	1.57 (40)	2.17 (55)	2.64 (67)	2.68 (68)	2.95 (75)	3.35 (85)	3.94 (100)

# Specification

## BOLT PATTERNS

### BOLT PATTERN - CHG2

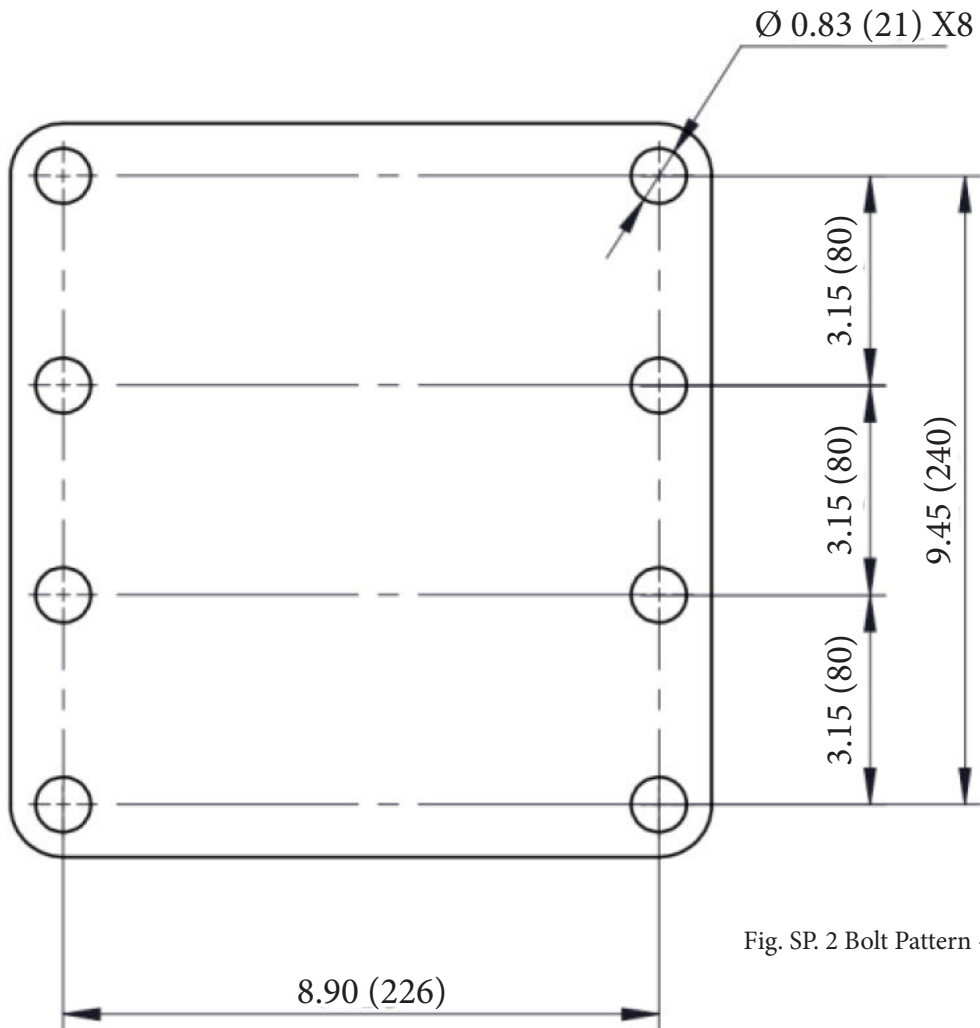

Fig. SP. 2 Bolt Pattern - CHG2

CHG2  
Inches (mm)

# Specification

BOLT PATTERN - CHG3, CHG6, CHG7

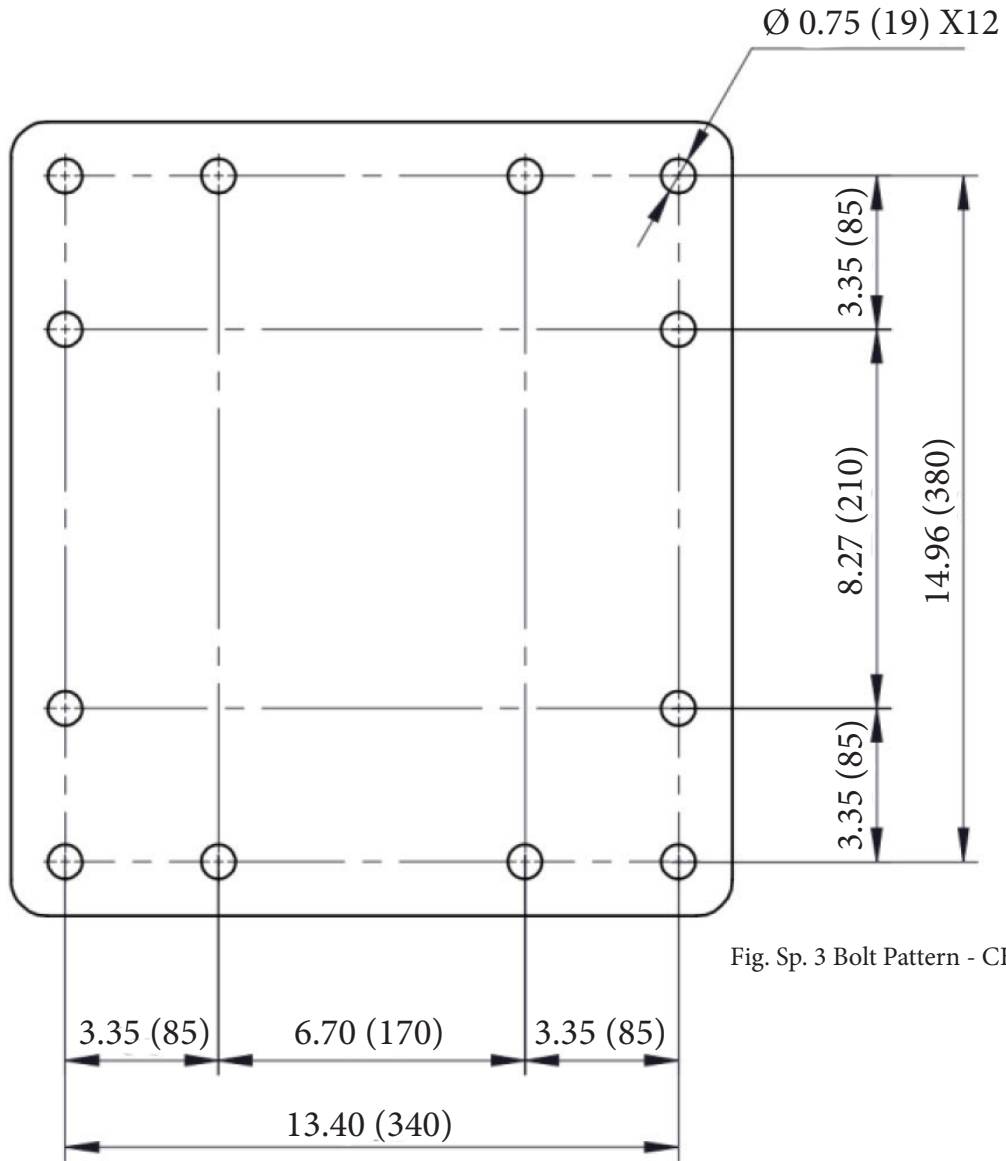

Fig. Sp. 3 Bolt Pattern - CHG3, CHG6, CHG7

CHG3, CHG6, CHG7  
Inches (mm)

# Specification

BOLT PATTERN - CHG9 & CHG10

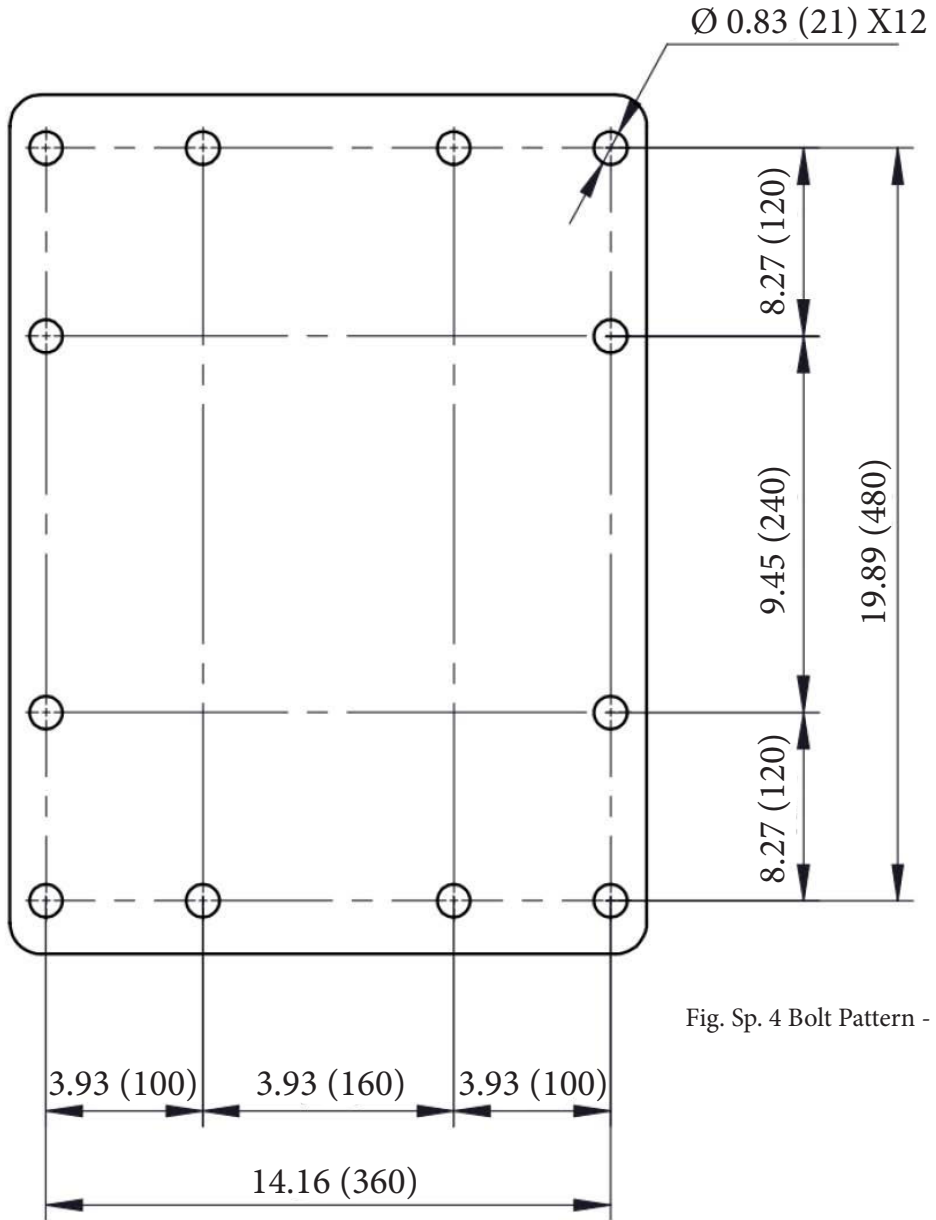

Fig. Sp. 4 Bolt Pattern - CHG9, CHG10

CHG9 & CHG10  
Inches (mm)

# Specification

BOLT PATTERN - CHG15

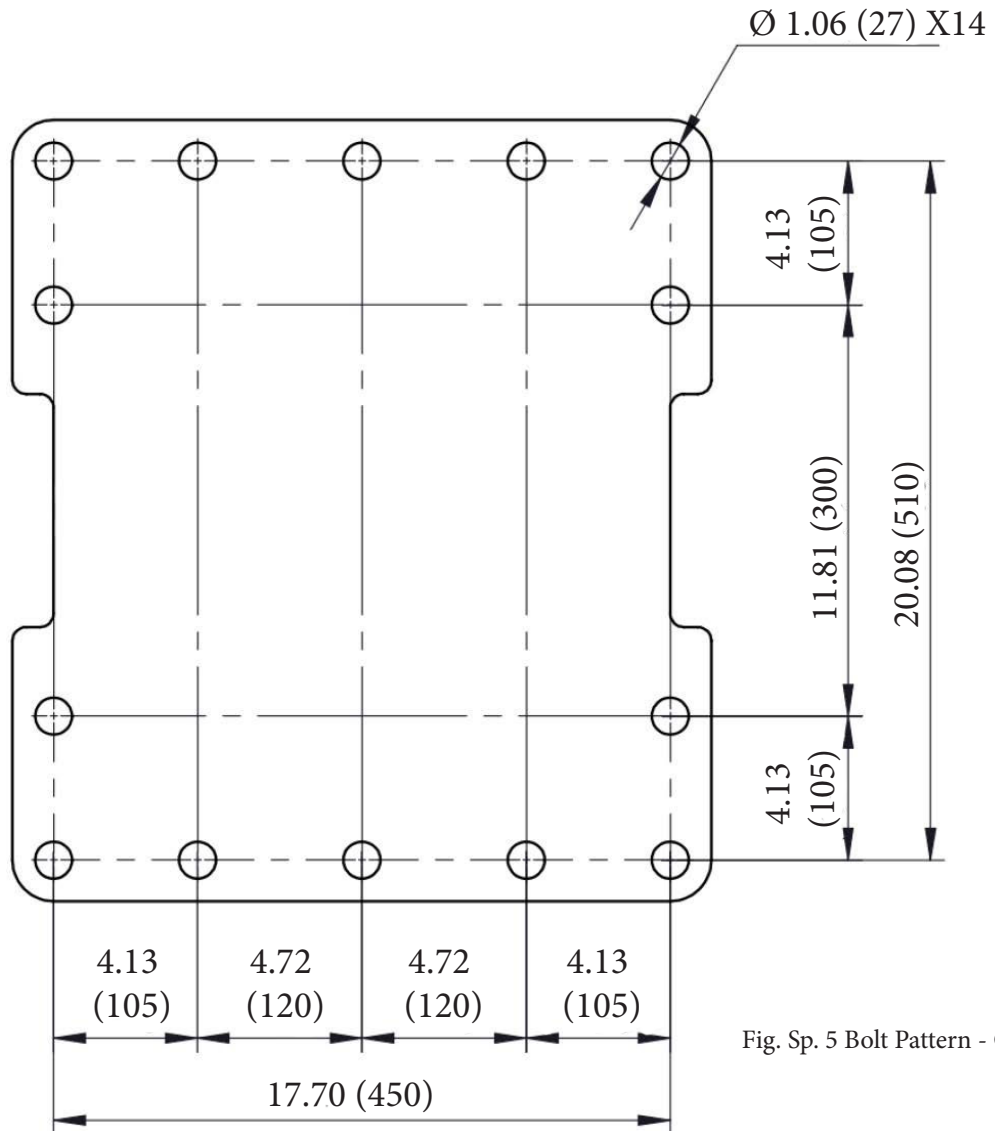

Fig. Sp. 5 Bolt Pattern - CHG15

CHG15  
Inches (mm)

# Specification

## TORQUE SPECIFICATIONS

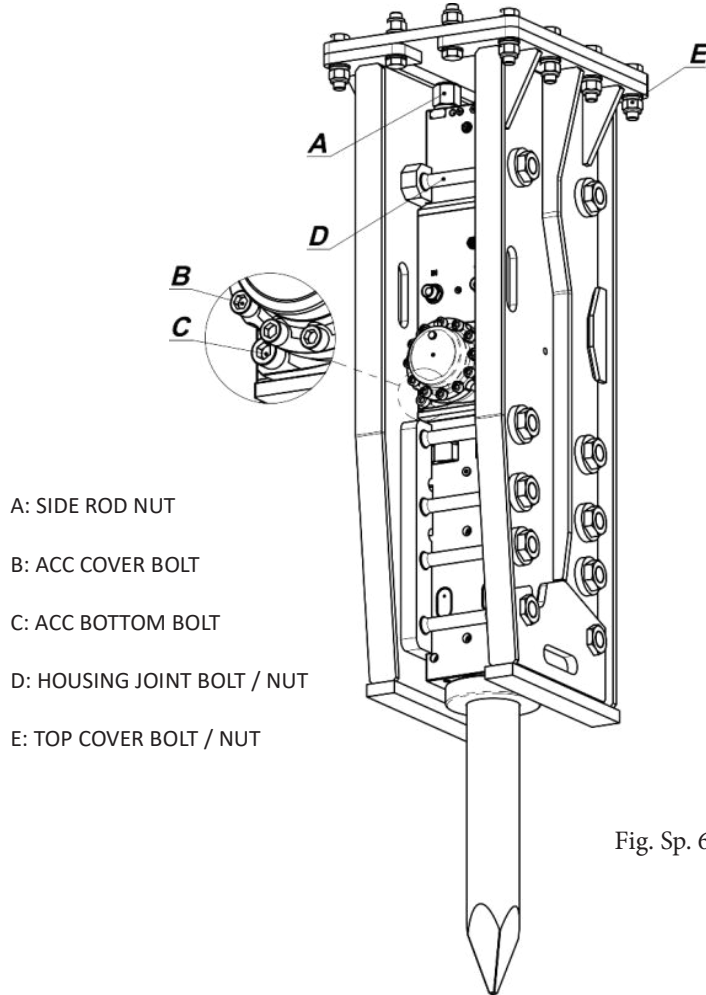

Fig. Sp. 6 Torque Specifications

DIMENSION	UNITS	CHG2	CHG3	CHG6	CHG7	CHG9	CHG10	CHG15
A	Ft/lbs (Nm)	221 (300)	332 (450)	332 (450)	443 (600)	664 (900)	1106 (1500)	1254 (1700)
B	Ft/lbs (Nm)	-	-	-	-	-	-	-
C	Ft/lbs (Nm)	-	-	-	-	-	-	-
D	Ft/lbs (Nm)	258 (350)	258 (350)	258 (350)	590 (800)	590 (800)	1254 (1700)	1254 (1700)
E	Ft/lbs (Nm)	221 (300)	221 (300)	221 (300)	221 (300)	221 (300)	221 (300)	479 (650)



# Operation

## OPERATION

### GUIDE TO TOOL CHOICE

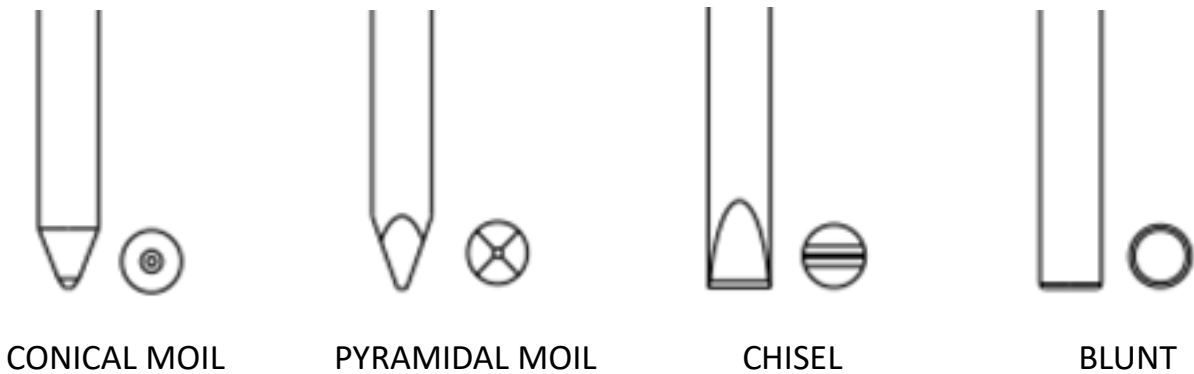

Fig. O1. Tool Choice

TOOL TYPE	UNITS	CHG2	CHG3	CHG6	CHG7	CHG9	CHG10	CHG15
CONICAL MOIL Very good penetration Soft and nonabrasive rock General demolition	Inches (mm)	19.6 (500)	22.8 (580)	24.3 (618)	27.4 (697)	31.5 (800)	35.2 (895)	35.4 (900)
	Pound (Kg)	9.7 (4.4)	18.3 (8.5)	33.1 (15)	38.8 (17.6)	50.7 (23)	79.4 (36)	107.4 (48.7)
PYRAMIDAL MOIL Maximum penetration Soft and Nonabrasive rock	Inches (mm)	19.6 (500)	22.8 (580)	24.3 (618)	27.4 (697)	31.5 (800)	35.2 (895)	35.4 (900)
	Pound (Kg)	9.7 (4.4)	21.2 (9.6)	33.7 (15.3)	37.5 (17)	48.5 (22)	76.3 (34.6)	104.5 (47.4)
CHISEL Medium penetration Nonabrasive but ductile rock	Inches (mm)	19.6 (500)	22.8 (580)	24.3 (618)	27.4 (697)	31.5 (800)	35.2 (895)	35.4 (900)
	Pound (Kg)	9.9 (4.5)	21.6 (9.8)	35.5 (16.1)	38.6 (17.5)	50.7 (23)	78.5 (35.6)	109.6 (49.7)
BLUNT Very good energy transfer Hard and abrasive rock Secondary breaking	Inches (mm)	19.6 (500)	22.8 (580)	24.3 (618)	27.4 (697)	31.5 (800)	35.2 (895)	35.4 (900)
	Pound (Kg)	10.4 (4.7)	22.9 (10.4)	37.5 (17)	41.2 (18.7)	52.9 (24)	78.9 (35.8)	115.1 (52.2)

## Operation

### PREPARING FOR INSTALLATION

Before installation of the breaker, the setup of hydraulic system of the excavator should be verified.

Check whether the relief pressure setting is acceptable as per specification of the breaker model. If the relief pressure is not correct, the relief valve should be adjusted so that the relief pressure value is within the specified range.

Check with which engine dial the oil flow at the specified operating pressure is acceptable as per specification of the breaker model , and operate the breaker with the engine dial In case of the excavator having an oil flow control valve, the oil flow control valve should be adjusted so that the oil flow at the specified operating pressure value is within the specified range.

### PIPE FLUSHING

After setting of relief pressure finished, make a direct connection between the pressure line and the return line of the excavator and be sure to flush the hydraulic oil pipe line. This is done to remove scale, dirt or dust which may remain in the piping.

When the both lines are connected, fully open the pressure and return line stop valves and push the pedal to flush the hydraulic oil pipe line. For efficient flushing work, alternately press and release the pedal to form pulsation in the pipeline.

The pipe flushing should be done at least 20 minutes.

After flushing work, discharge air from the hydraulic oil tank, clean the line filter element and remove the foreign particles.

### INSTALLATION TO EXCAVATOR

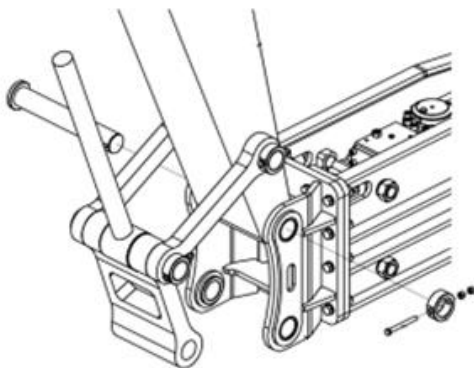

Fig. O3. Installation to Excavator

1. Lay the hydraulic breaker horizontal with the valve block facing upward.
2. The top bracket bushings should be in place.
3. Align the main pin hole of the arm with the rear pin hole of the top bracket.
4. Insert the main pin and mount the stopper with bolt and nuts.
5. Align the link pin hole of the arm with the front pin hole of the top bracket.
6. Insert the link pin and mount the stopper with bolt and nuts

## Operation

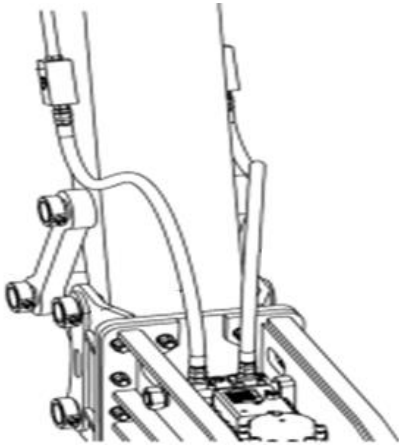

Fig. O4. Installation to Excavator

7. Connect the in line and out line hoses to the stop valves.
8. Turn the pressure line stop valve fully open and then the return line stop valve fully open.

### REMOVAL FROM CARRIER

1. Lay down the hydraulic breaker horizontal with the valve block facing upward.
2. Turn the pressure and return line stop valves to the fully closed position.
3. Disconnect the in line and out line hoses
4. Remove the link pin and then the main pin.

### 3-6. ADJUSTMENT OF BPM AND POWER

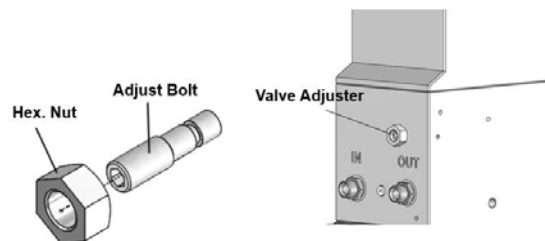

Fig. O5. BPM and Power adjustment

Hammer BPM and impact power can be adjusted by changing the turns of the valve adjuster.

Tightening the adjust bolt will increase power and decrease BPM. On the other hand, loosening the adjust bolt will decrease power and increase BPM. When the hammer is first released, the adjust bolt is set to be 2.5 turns open from the fully tightened position.

#### ADJUSTING OF THE VALVE ADJUST

1. Slightly loosen the hex. nut by turning it counterclockwise.
2. Turn the adjust bolt to tighten (clockwise) or loosen (counterclockwise) for BPM and power adjustment.
3. After finishing the adjustment, turn the hex. nut to tighten it securely.

## Operation

### ADJUSTMENT OF AUTO SHUT-OFF SYSTEM (CHG15)

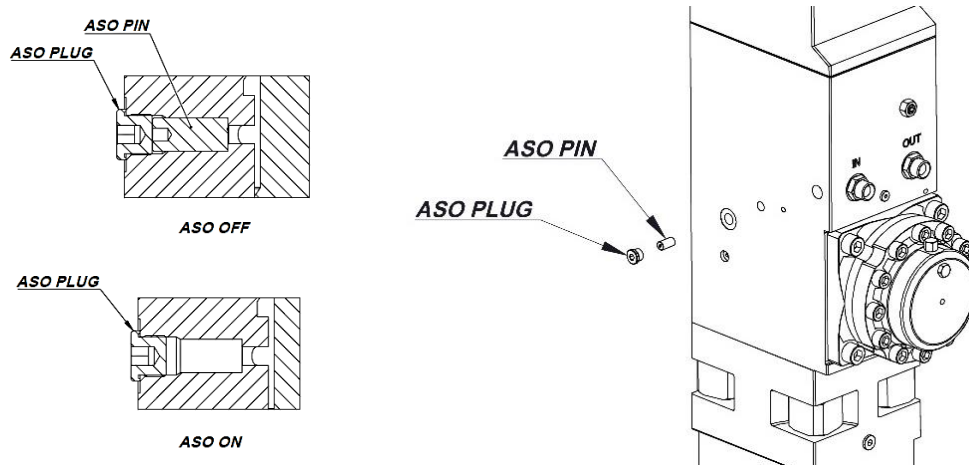

Fig. O5. Auto Shut-off system (CHGE15) adjustment

One of the most potentially damaging events in a breaker's life is blank firing. Blank firing is when the piston slams down to the bottom of its stroke without contacting the tool, the energy which should have been transmitted to the workpiece is absorbed in the breaker body. This can cause so much damage to the inside of a breaker. To lessen the effect of blank firing, Auto Shut Off (ASO) system is available.

The operator can selectively adjust On & Off Modes of Auto Shut Off function according to the given working condition.

The Auto Shut-Off PLUG is on the right side of the cylinder.

In ASO On Mode, the hammer automatically stops when the tool tip is no longer in contact with the material. It reveals its benefits in a work condition where visibility is poor (e.g. underwater). This reduces the strain on breaker, and ultimately increases the hammer lifespan.

In ASO Off Mode, the breaker starts without load applied to the tool, thus simplifying handling by saving time to position the breaker. This provides great productivity through increased efficiency of hammer operation.

Standard factory setting is ASO On mode which preventing no load stroke.

#### Adjusting of the modes

##### 1. Switching to ASO Off Mode

- A. Untighten ASO Plug.
- B. Install ASO PIN (You can find ASO Pin in the toolbox).
- C. Retighten ASO Plug.

##### 2. Switching to ASO On Mode

- A. Untighten ASO Plug.
- B. Remove ASO PIN (Keep the ASO PIN well for reuse).
- C. Retighten ASO Plug.

# Maintenance

## MAINTENANCE

### PRODUCT SERIAL NUMBER

The serial number is stamped on the back head of the power cell. It is important to make correct reference to the serial number of the machine when asking for repairs or ordering spare parts. Identification of the serial number is the only proper means of maintaining and identifying parts for a specific product.

### PERIODIC MAINTENANCE

#### Daily Basis Inspection

- Grease the demolition tool every 2 hours.
- Check loose of the hydraulic hoses and retighten as necessary.
- Check for oil leaks and consult with dealer for further inspection.

#### Weekly Basis Inspection

- Check for loose items on the side rods and retighten if necessary
- Check for loose items on the housing joint bolts and the top cover bolts and retighten if necessary.
- Check for damaged or missing bushing pins, plugs and snap rings. Replace if necessary.
- Check for cracks in the housing and the top bracket
- Check the gas pressure in the back head and recharge if necessary

#### Basis Inspection

- Check wear of the demolition tool, the tool pins, the tool bushings and replace them when wear exceeds the wear limits.
- Check the damping elements and wear plates for wear and replace them when wear exceeds the maximum clearance limits.
- Check the oil filter of the carrier and replace if necessary.

#### Six Month Basis Inspection

- Check if every part of the power cell and verify that here in good condition.
- Check the gas pressure in the accumulator and recharge if necessary.
- Check the torque of every bolt and nut and tighten to the correct torque specifications.
- Check every seal and accumulator membrane and replace them if necessary

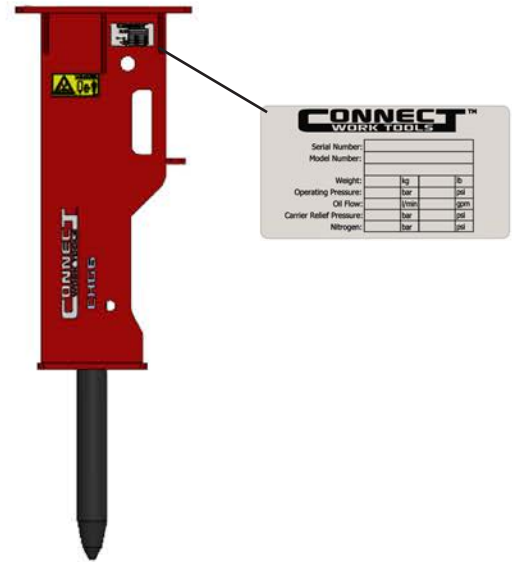

Fig. M1 Serial Number location

## Maintenance

### NITROGEN GAS CHARGING OF BACK HEAD

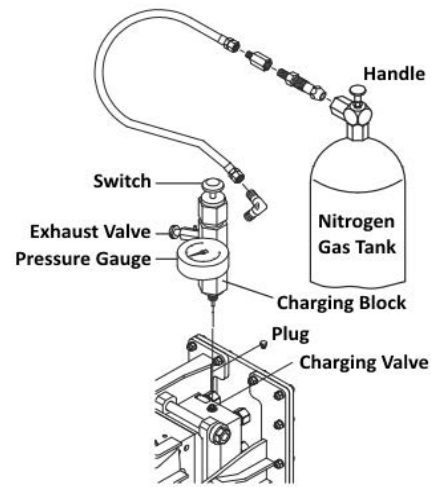

Fig. M2 Nitrogen gas charging of back head

1. Install the pressure gauge on the charging block.
2. Turn the handle of the charging block clockwise to close the exhaust valve.
3. Connect one end of the gas hose to the nitrogen gas tank.
4. Connect the other end of the gas hose to the charging block.
5. Remove the plug from the charging valve on the power cell.
6. Install the charging block to the charging valve of the back head (Ensure that an O-ring is installed on the charging block).
7. Slowly turn the handle of the nitrogen gas tank counterclockwise to charge nitrogen gas in the back head (Ensure that the exhaust valve of the charging block is fully closed).
8. Shut off the nitrogen gas tank by turning the handle clockwise. Press the switch of the charging block to check the gas pressure inside the back head (The gas pressure shown while pressing the switch is the actual gas pressure level inside the back head).
9. After checking the gas pressure in step 8. Set the gas pressure to 5-10 bar more than the specified pressure level in the specification, then slowly open the exhaust valve while continuously pressing on the switch to discharge excess nitrogen gas until the gas pressure drops down to the specified pressure level in the specification.
10. When the gas pressure is set to the specified pressure level, release the switch and open the exhaust valve to discharge the nitrogen gas from the gas hose.
11. Remove the charging block from the charging valve.
12. Check for the gas leakage using soap bubbles around the charging valve.
13. Install the plug.

## Maintenance

### LUBRICATION

Metal to metal contact causing pick up could cause deep damage marks which, in turn, lead to the formation of fatigue cracks and eventual failure of the demolition tool.

When greasing, make sure the demolition tool is firmly pressed into the front head. Do not apply excessive grease. Otherwise, the grease will go into the top of the demolition tool. This may lead damage of the seals at the lower cylinder due to excessive pressure and contaminate the hydraulic oil.

Grease injection should be done every two hours. Ensure that the tool shank is well lubricated. 5-10 strokes from grease gun to upper and lower tool bushings willenough.

SEOAN recommends a lithium soap thickener base NLGI grade 2 grease with molybdenum disulfide (MoS<sub>2</sub>) as solid lubricants and high dropping point (500°F 260°C). Temperature range of -20°F~-450°F (-30°C~230°C) is desirable.

By installing the auto grease pump, the grease injection can be done automatically. Both cartridge type pump and refill type pump are available.

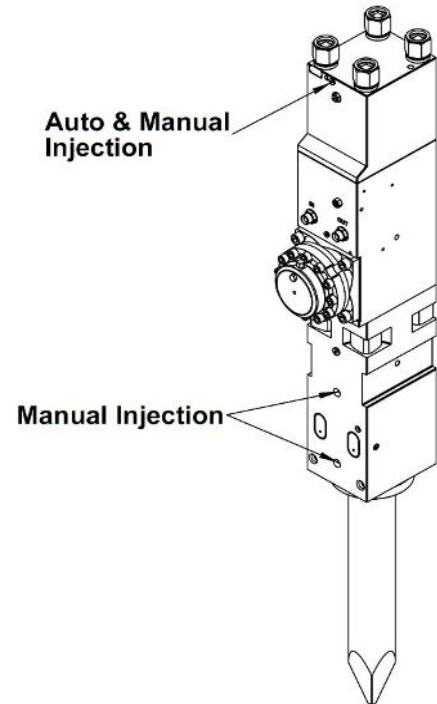

Fig. M3 Lubrication

# Maintenance

## PROHIBITED OPERATION

### Lifting or Moving Loads

Do not lift or move loads with the breaker. The lifted loads may fall and cause serious injuries or death. Moving objects with the demolition tool or the housing may lead broken tool or deformed housing.

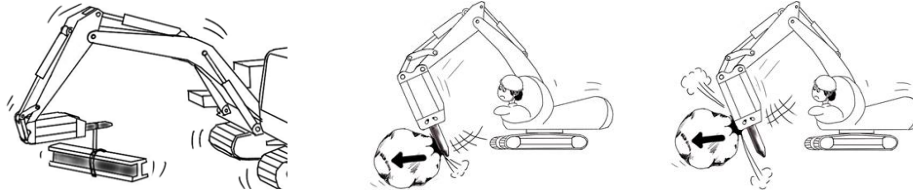

### Underwater Application without Underwater Setting

Do not operate the breaker under water without supplied air pressure setting. This may cause damage to the hydraulic breaker. When using the breaker underwater, contact the dealer for underwater instructions.



### Slant Hammering

Always keep hitting the material at a right angle. Slant hammering will add unnecessary stress and bending force to the demolition tool and tool bushings, which may lead rapid wear of consumable parts and possibly failure of the hydraulic breaker.



### Continuous Hammering on same spot

Do not apply the hydraulic breaker on the same spot for more than 15 seconds. The demolition tool will become hot and lose its hardness so that the end of the demolition tool may become distorted.

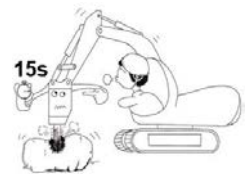

### Operating at Cylinder End Positions

Do not operate the hydraulic breaker with carrier stick and bucket cylinders at fully extended or fully retracted positions. This may cause damage to the carrier cylinders.

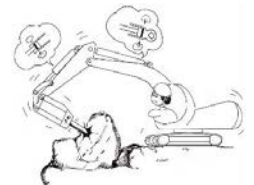

### Prying or Levering

Do not use the demolition tool as a pry bar. Prying or bending work may cause premature wear of the tool bushings and failure of the demolition tool.





# Maintenance

## INSPECTION OF WEAR CONDITION

Replace the demolition tool, lower bushing, upper bushing, and toolpin when the wear condition reaches the maximum clearance. According to the charts below:

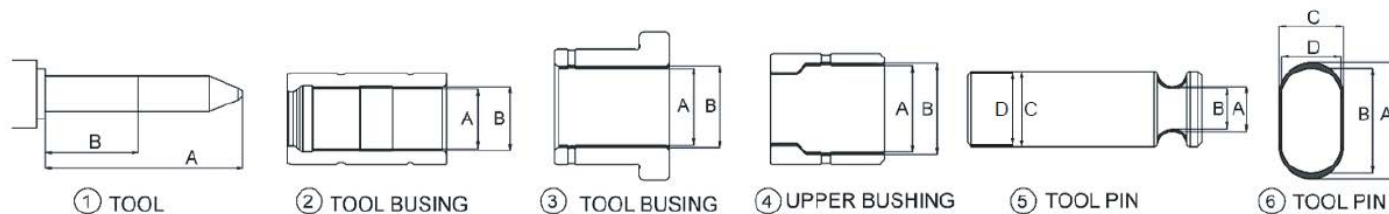

MODEL	UNITS	1 - TOOL		2 - TOOL BUSHING		3 - TOOL BUSHING		4 - UPPER BUSHING		5 - TOOL PIN		6 - TOOL PIN	
		A	B	A	B	A	B	A	B	A	B	A	B
CHG2	Inch (mm)	13.5 (343)	9.1 (230)	1.8 (48)	1.9 (50)	-	-	-	-	0.8 x 1.2 (21.5 x 30)	0.7 x 1.0 (19.5 x 27)	-	-
CHG3	Inch (mm)	14.7 (373)	9.8 (250)	2.1 (55)	2.2 (57)	-	-	-	-	0.7 x 1.3 (18 x 32)	0.6 x 1.1 (16 x 29)	-	-
CHG6	Inch (mm)	15.0 (381)	11.1 (281)	-	-	2.6 (67)	2.7 (69)	2.6 (67)	2.7 (69)	1.3 x 1.6 (35.5 x 41)	1.2 x 1.5 (33.5 x 39)	-	-
CHG7	Inch (mm)	16.6 (422)	12.7 (322)	-	-	2.7 (68)	2.8 (70)	2.7 (68)	2.8 (70)	0.8 x 1.1 (20 x 30)	0.7 x 1.0 (18 x 27)	-	-
CHG9	Inch (mm)	19.6 (497)	13.0 (330)	-	-	2.9 (75)	3.0 (77)	2.9 (75)	3.0 (77)	1.1 (29)	1.0 (27)	-	-
CHG10	Inch (mm)	21.3 (542)	13.8 (350)	-	-	3.3 (85)	3.4 (87)	3.3 (85)	3.4 (87)	-	-	2.1 x 1.2 (54 x 30)	2.0 x 1.0 (51 x 27)
CHG15	Inch (mm)	18.4 (467)	10.5 (267)	-	-	3.9 (100)	4.0 (102)	3.9 (100)	4.0 (102)	-	-	2.3 x 1.2 (60 x 32)	2.2 x 1.1 (57 x 29)

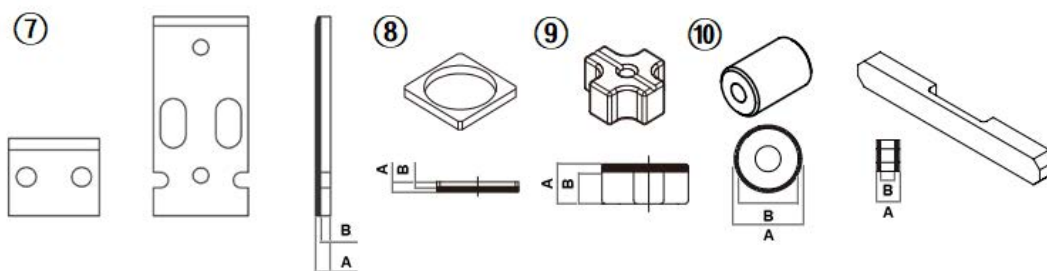

MODEL	UNITS	7 - WEARING PLATE				8 - BASE BUFFER		9 - TOP BUFFER		10 - SIDE BUFFER	
		A	B	A	B	A	B	A	B	A	B
CHG2	Inch (mm)	0.4 (10)	0.3 (8)	-	-	0.8 (20)	0.7 (18)	2.1 (55)	2.0 (53)	-	-
CHG3	Inch (mm)	0.4 (10)	0.3 (8)	-	-	0.8 (20)	0.7 (18)	2.1 (55)	2.0 (53)	-	-
CHG6	Inch (mm)	0.5 (12)	0.4 (10)	-	-	0.8 (20)	0.7 (18)	2.7 (70)	2.6 (68)	1.9 (50)	1.8 (48)
CHG7	Inch (mm)	0.5 (12)	0.4 (10)	-	-	0.8 (20)	0.7 (18)	2.7 (70)	2.6 (68)	1.9 (50)	1.8 (48)
CHG9	Inch (mm)	0.5 (12)	0.4 (10)	-	-	0.8 (20)	0.7 (18)	3.3 (85)	3.2 (83)	3.1 (80)	3.0 (78)
CHG10	Inch (mm)	0.6 (16)	0.11 (14)	-	-	0.8 (20)	0.7 (18)	3.3 (85)	3.2 (83)	3.9 (100)	3.8 (98)
CHG15	Inch (mm)	0.6 (16)	0.11 (14)	0.8 (20)	0.7 (18)	0.8 (20)	0.7 (18)	3.9 (100)	3.8 (98)	1.1 (28)	1.0 (26)

## Important Storage Procedure

### SHORT-TERM STORAGE

For short term storage between usage, place the breaker horizontal on wooden blocks. Make sure that the tool is lubricated, and the hydraulic hoses are securely capped. Cover the breaker with a waterproof tarp.

### LONG-TERM STORAGE

Check the followings for safe long-term storage of the breaker to prevent rust and make breaker ready for next use.

- Breaker must be stored in upright position.
- If back head is charged with N2 gas, the front head of the piston is protruded from the cylinder.
- Remove the tool and push the piston all the way in.
- Grease the exposed front end of the piston.
- Plug the hydraulic hoses.
- Cover the breaker with a waterproof tarp

### CORRECT GREASING

When manually greasing a CHG Series Breaker, the breaker must be in the upright position with down force on the tool bit. Do not lubricate the breaker in the horizontal position or laying on the ground. Failure to lubricate the breaker in the upright position with the tool bit installed will fill the tool bit chamber with grease resulting in damage to the breaker seals, pushing them out of the cylinder when the breaker is operated.

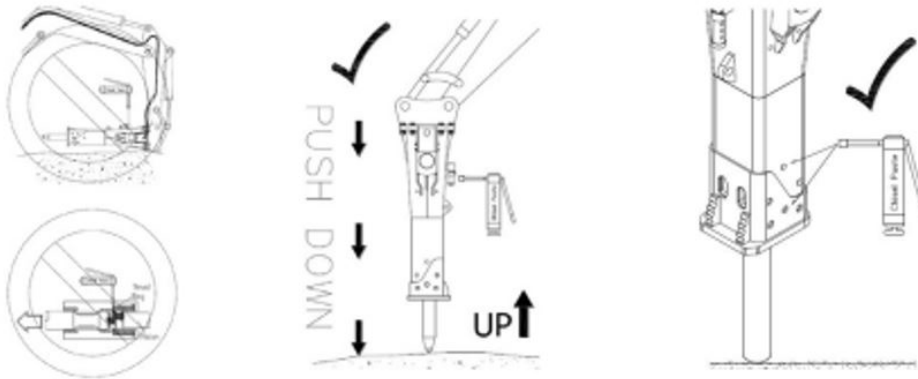

Automatic Lubrication Automatic lubrication methods can be installed on all Connect Work Tools models. The breakers are equipped with top-down lubrication. The tool grease is supplied from the pump into the breaker by hose. This is recommended for longer service life of wear parts.



## Breaker Inspection Form

Location/ Branch	
Customer	
Inspection Date	
Time	
Attachment Description	
Model	
Serial Number	

Breaker Check inspection:	YES	NO	Notes
Missing Plugs, Pins, bolts			
Check for Oil leaks (before testing)			
Signs of grease around tool			
Measure Tool/ Bushing Wear			Note space between tool and bushing see spec (mm)
Measure Tool Length			Note tool length see spec (mm/in)
Remove tool and check for excessive bushing wear wear. Check for signs of blank fire			
Check Hoses and fitting for Damage			
If no hose. Caps need to be installed			
Does unit have auto lube system?			
Has correct grease been used?			
Ensure breaker is correctly greased before testing or putting back in service			
Test breaker for operation on hard surface (Thick metal plate if available)			If correct operation is questionable. Please consult operation manual. Please contact Product support Johnnie Gibbons at (512-565-3578) johnnie@connectworktools.com
Remarks:			Correct Action Needed:
Inspected By			

## Accessory Tools

### ACCESSORY TOOLS

MODEL	UNITS	CHG2	CHG3	CHG6	CHG7	CHG9	CHG10	CHG15
TOOL BOX	SMALL	1	1	1	1	1		
	MEDIUM							
	LARGE						1	1
SINGLE SPANNER	0.75 (19)							
	0.86 (22)							
	0.94 (24)							1
	1.06 (27)	2	2	2	2	2	2	
	1.18 (30)	1	1					
	1.26 (32)			1	1			
	1.42 (36)			1	1	1	1	2
	1.50 (38)						1	1
	1.81 (46)							
	1.97 (50)							
	2.17 (55)							
HAMMER SPANNER	1.42 (36)		1			1		
	1.61 (41)				1			
	1.97 (50)						1	
	2.17 (55)							1
	2.76 (70)							
	3.54 (90)							
DOUBLE SPANNER	0.67 X 0.75 (17 X 19)							1
L-WRENCH	0.31 (8)			1	1	1	1	1
	0.39 (10)					1	1	1
	0.47 (12)							
	0.55 (14)						1	1
T-WRENCH	0.20 (5)	1	1	1	1	1	1	
EYE BOLT	M6						1	
	M8							1
SOCKET BOLT	M8 X 1.25p 3.54 (90)							1
PIN BAR	Ø 0.24 (6)	1						
	Ø 0.31 (8)			1				
	Ø 0.47 (12)		1			1		1
	Ø 0.55 (14)				1		1	
SNAP RING PLIER	0.47 X 2.56 (12 X 65)					1	1	1
DRIVE (-)	5.91 (150)					1	1	1
GREASE GUN	500cc	1	1	1	1	1	1	1

# Troubleshooting

## TROUBLESHOOTING

### Hammer Does Not Start

Cause	Remedy
Pressure & return lines swapped	Check hydraulic line connections.
Stop valves closed	Check them and open.
Gas pressure in back head too high	Check the pressure and adjust as needed.
Operating valve jammed	Check smooth moving of operating valve
Poor performance of hydraulic pump	Contact the carrier manufacturer

### Low Impact Force

Probable cause	Remedy
Gas pressure in back head too low	Check gas pressure and recharge as needed.
Relief pressure setting too low	Check relief pressure and adjust as needed.
Poor performance of hydraulic pump	Check the pump characteristics and contact the carrier manufacturer

### Slow Operation

Probable cause	Remedy
Loosened connection	Check connection fittings and tighten.
Oil leakage	Check damaged seals and replace them.
Stop valves partly closed	Check them and fully open.
Gas pressure in back head is too high	Check the pressure and adjust as needed.
Accumulator membrane defective	Check and replace as needed.

### Impact Rate Too High and Impact Force Too Low

Probable cause	Remedy
No gas in accumulator	Check the gas pressure and recharge as needed.
Accumulator membrane defective	Check and replace as needed.

### Irregular Blow after Normal Operation

Probable cause	Remedy
Oil temperature too high	Check oil level and top up oil. Check cooler of the carrier.
Poor performance of hydraulic pump	Contact the carrier manufacturer
Clearance between demolition tool and tool bushings too large	Check the clearance and replace as needed
Wear on top of demolition tool	Dismantle and replace it.
Foreign material in operating valve	Dismantle and clean it.
Seizure of piston and cylinder	Dismantle and check the breaker.

# Dismantling

## DISMANTLING

### REMOVING THE TOOL

CHG2 ~ CHG7

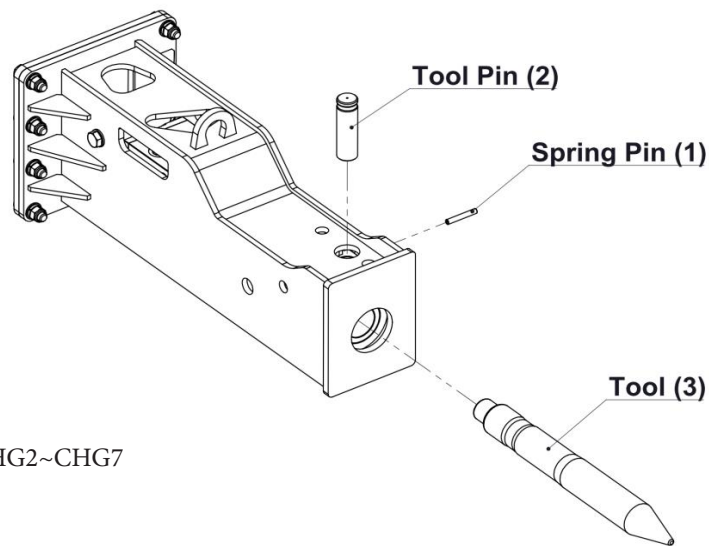
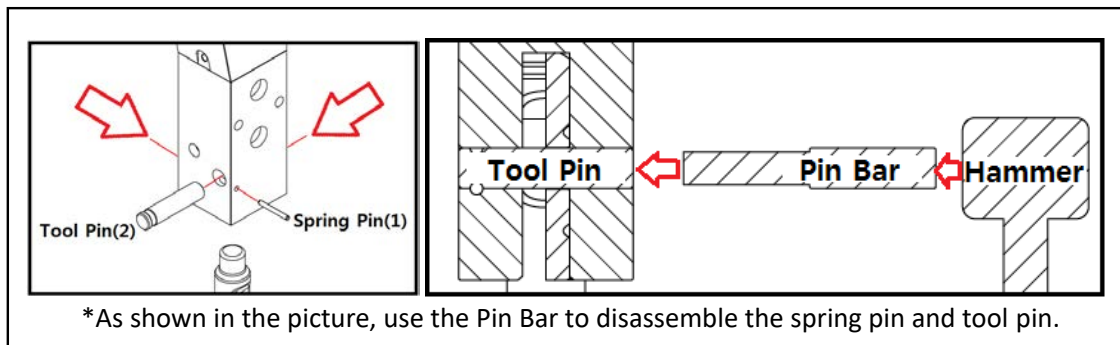

Fig. D1 CHG2~CHG7

1. Put the square wooden bar on the flat ground and lay the breaker on the square dowl of wood.
2. INSERT Pin bar in the direction of the arrow and strike with hammer in order for the spring pin (1) to come out.
3. After dismantling Tool pin (2), Insert Tool (3)



\*As shown in the picture, use the Pin Bar to disassemble the spring pin and tool pin.

Fig. D2 CHG2~CHG7 Pin removal

4. Assemble in reverse order
5. Inject grease

# Dismantling

CHG9

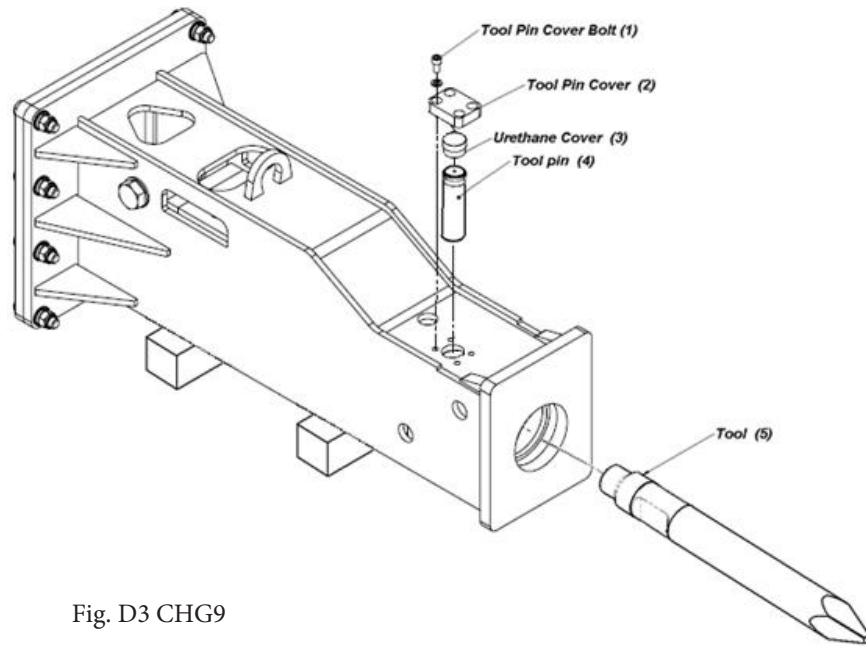

Fig. D3 CHG9

1. Put the square wooden bar on the flat ground and lay the breaker on the square dowel of wood.
2. Unscrew Tool pin cover bolt(1).
3. After dismantling Tool pin cover (2) and urethane cover(3), take out Tool pin(4)

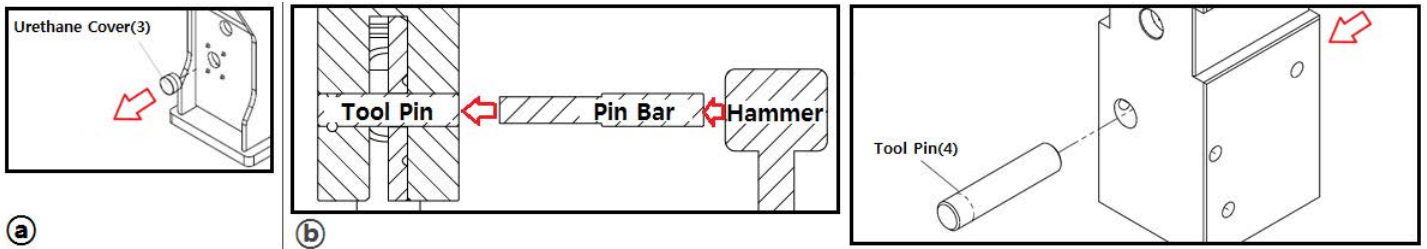
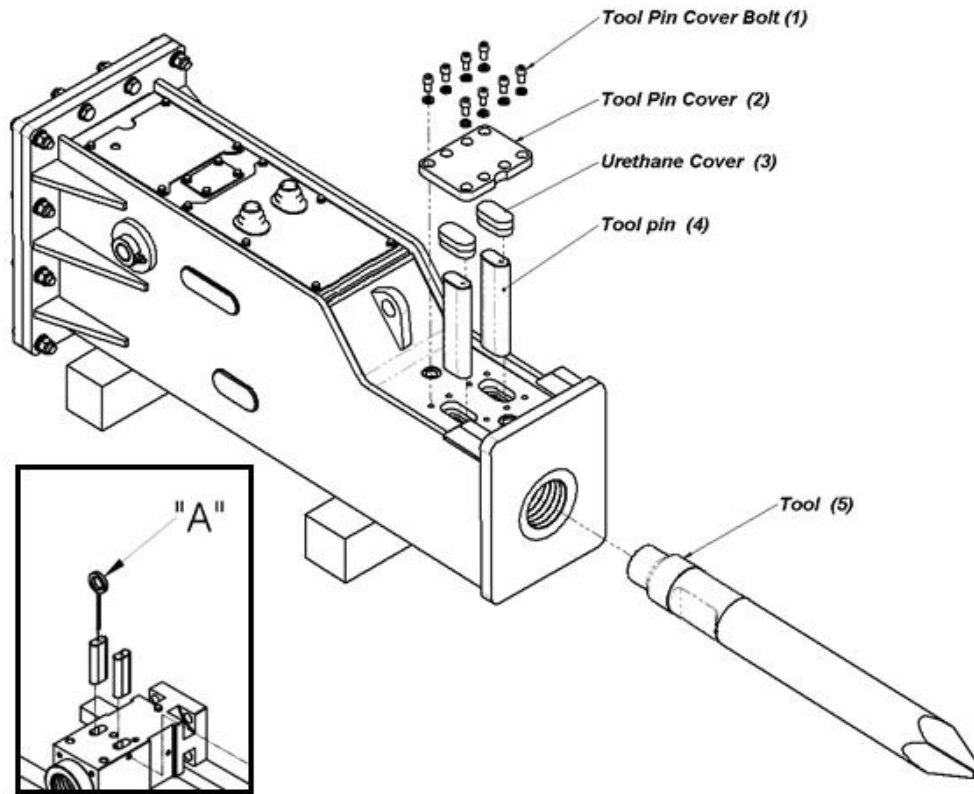

Fig. D3 SM9 Pin removal

- a. Pull out the urethane cover(3) with pliers.
- b. Use a hammer to disassemble the tool pin(4) in the direction shown.
4. After inserting the tool, assemble in reverse order.
5. Inject grease

## Dismantling

CHG10 & CHG15



MODEL	"A" EYE BOLT
CHG10	M6 x 1.0P
CHG15	M8 x 1.25P

Fig. D5 CHG10 & CHG15

1. Put the square wooden bar on the flat ground and lay the breaker on the square dowl of wood.
2. Unscrew Tool pin cover bolt (1).
3. AFTER dismantling Tool pin cover (2) and Urethane cover (3), take out Tool pin (4) by using Eye bolt (M8).
4. After inserting the tool, assemble in reverse order.
5. Inject grease



## Dismantling

### DISASSEMBLE THE HAMMER POWERCELL

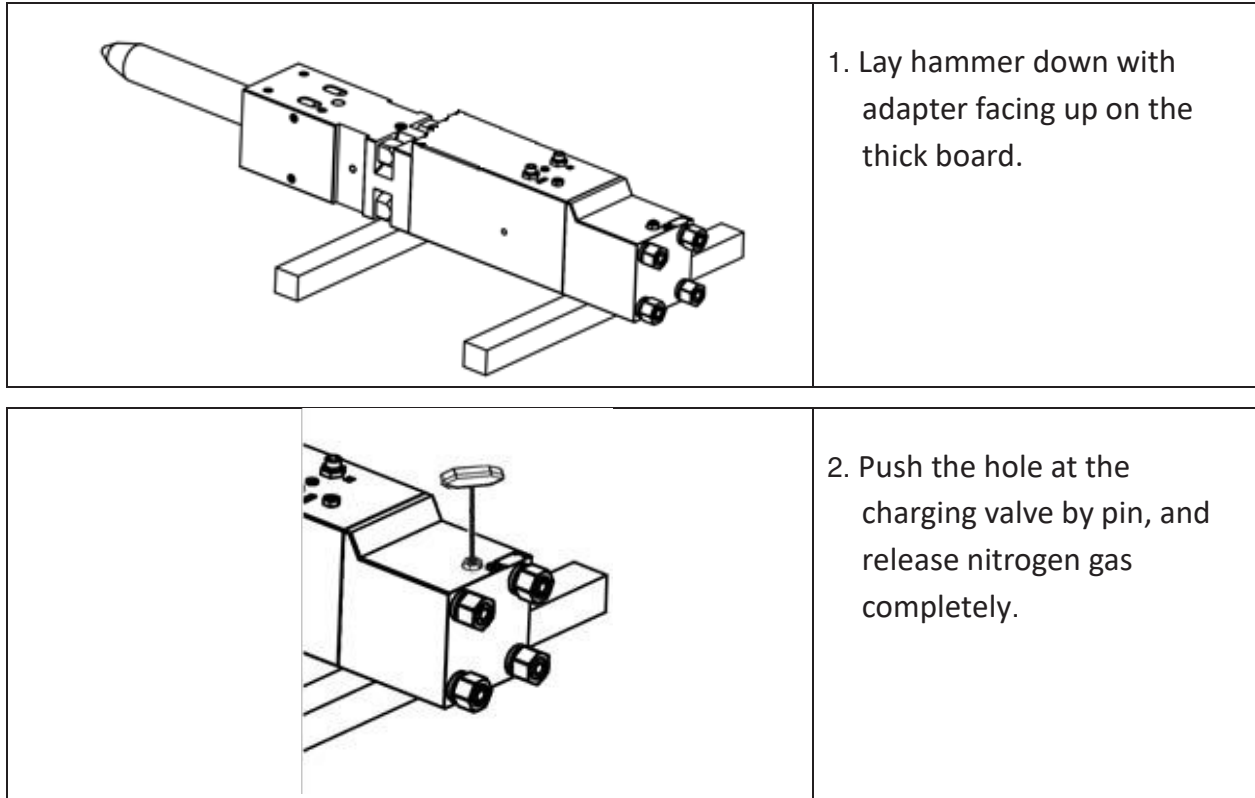

Fig. D6 Powercell (1)



Before disassembling breaker, all remaining gas should be discharged completely from back head. Otherwise, it could result in serious injury or death.



Wear goggles to protect eyes from discharging gas or dust emission. Don't be too close to the gas charging valve.

## Dismantling

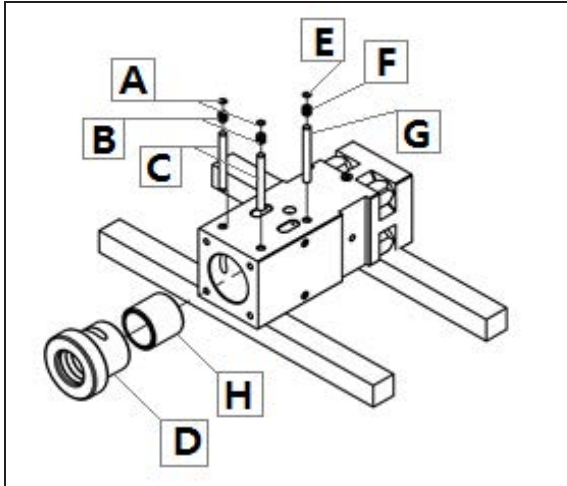

Fig. D7 Powercell (2)

1. Remove the snap-ring (A), rubber plug (B), and bushing pin (C)
2. Pull out the lower tool bushing (D)
3. Remove the snap ring (E), rubber plug (F), and upper bushing pin (G) to remove upper bushing (H).

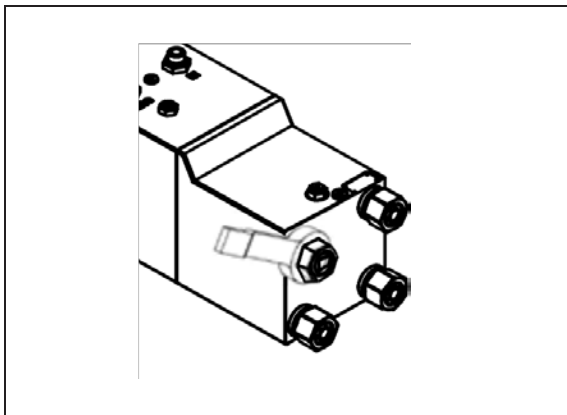

Fig. D8 Powercell (3)

Loosen the side rod nut with ring wrench. Before standing up the power cell, retighten the side rod nut by hand to prevent the inner parts from being damaged.



Back head nitrogen charge **MUST** be released before removing side rods.

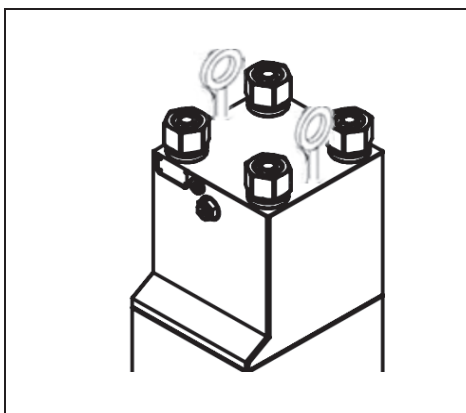
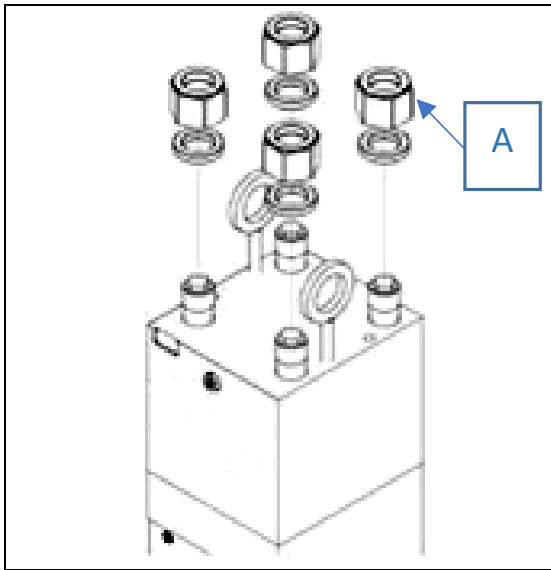

Fig. D9 Powercell (4)

Stand the power cell vertically using eye bolts. Secure hammer in stand for safety.

**\* The eye bolt is not included in the tool box.**

## Dismantling



Loosen and remove the side rod nuts & washers, and install lifting eye bolts into back head.

MODEL	DIAGRAM	TORQUE (FT/LBS)	TORQUE (N.m.)
CHG2	A	221	300
CHG3	A	332	450
CHG6	A	332	450
CHG7	A	443	600
CHG9	A	664	900
CHG10	A	1106	1500
CHG15	A	1254	1700

**\*The values in the table are the torque values required when decomposing "A"**

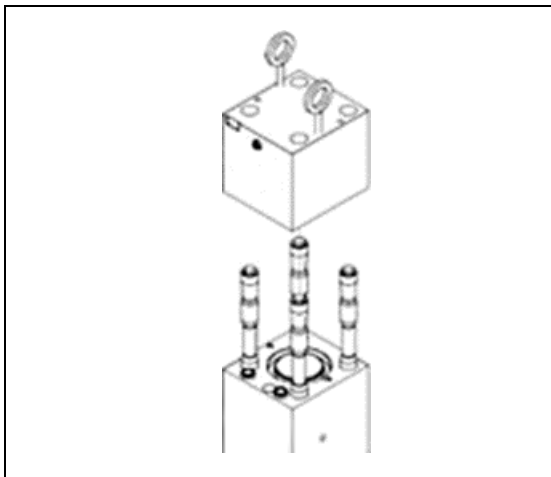

Disassemble the back head with crane.

Fig. D10 Powercell (5)



Be sure to use a crane to handle or move the heavy parts.

## Dismantling

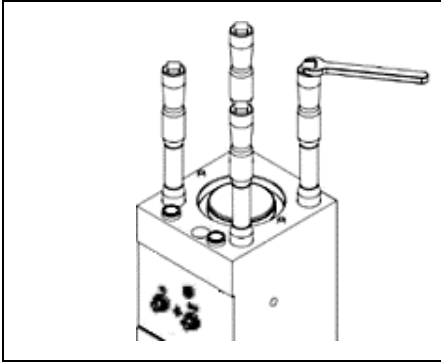

Loosen the side rod bolts with spanner. Check the threads for damage or cracks.

Note

Use dye check for detecting cracks

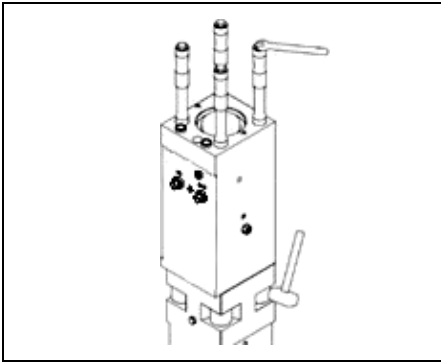

During loosening side rod, slightly hit the side rod lower nuts with a mallet for easy loosening.

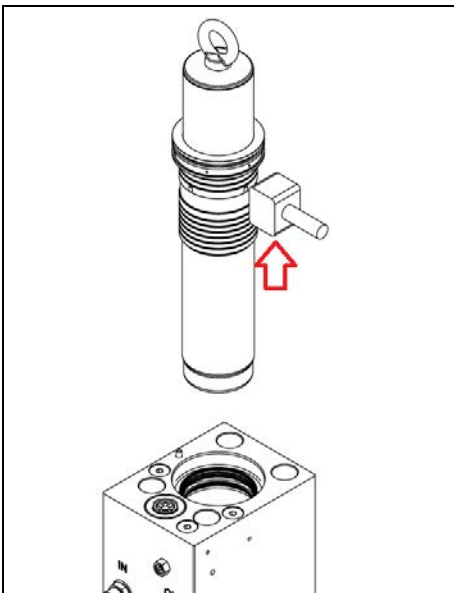

Install the eye bolt on the lifting point of piston and pull out the piston slowly. When you pull the piston out, seal housing will come up. To remove seal housing from piston, tap with rubber hammer.

Fig. D11 Powercell (16)

### NOTICE

Always you must pay attention to handle the core parts like piston, cylinder, seal housing valve block. Be careful to use rubber hammer if necessary, but do not damage the core parts.

## Dismantling



Pull out the piston slowly.

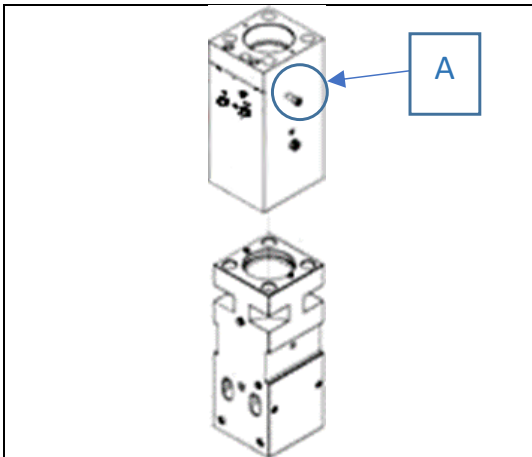

Remove the cylinder from front head.

**\* To lift the cylinder, attach a string to part "A" and lift.**

Fig. D12 Powercell (7)

*Notes*

---

---

---

---

---

---

---

---

---

---

---

---

---

---

---

---

---

---

---

---

---

---

---

---





**CONNECT**<sup>TM</sup>  
**WORK TOOLS**

---

**920.238.6657**

*[www.connectworktools.com](http://www.connectworktools.com)*

