

CM SERIES ELECTROMAGNETS

Get Connected. Stay Connected with CWT Magnets

TECHNICAL FEATURES

Hydraulic electromagnets with teeth are used in demolition, scrap, waste, C&D, and railroad applications.

The teeth are designed to rake debris, making it easier to extract ferrous materials. Teeth are also equipped with a quick fitting device and are easy to replace.

These electromagnets are equipped with a plate for quick hitch, providing the advantage that they can be attached without manual intervention.

Like all self-contained hydraulic magnets, it does not require an electrical connection. It is a fully hydraulic attachment that is designed to fit on excavators.

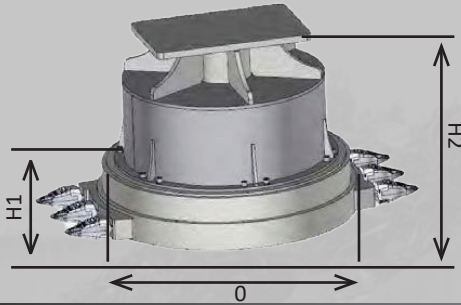

TECHNICAL DATA

CM SERIES HYDRAULIC MAGNET WITH TEETH				
MODELS	CM42ID	CM46ID	CM50ID	CM60ID
Machine weight (Ton) min-max	17 - 25	20 - 28	24 - 35	32 - 45
Min. Flow (GPM)	18	21	26	31
Max. Flow (GPM)	37	37	40	40
Max. Pressure (PSI)	2900	2900	2900	2900
Diameter (in) Ø	42	46	50	60
H base (in) H1	10	11	11	12
H including chain/plage (in) H2	32	32	32	33
Power (kW)	5.5	6	7.5	12
Weight (lbs)	3,197	3,417	4,079	6,393
Voltage (V)	220	220	220	220